

Aviation Jobs Transformation Report

2025



Foreword

by Director-General, CAAS and Chief Executive, WSG

Singapore's aviation industry has demonstrated remarkable resilience in its recovery from the unprecedented disruptions of COVID-19. Through the collective effort of leaders in the aviation ecosystem, Government agencies and Unions, the aviation community not only rebuilt its foundations but emerged more robust than ever.

As we look to the future, the momentum continues with the development of Changi Airport's Terminal 5, reflecting Singapore's ambition to strengthen our position as a leading aviation hub. This expansion will require transformation of job roles to meet evolving industry demands, and will generate fulfilling career opportunities in the sector. The adoption of automation and AI will only accelerate and the investment in building the career health of the aviation workforce is essential for the industry to remain resilient and agile and be future-ready.

The Aviation Jobs Transformation study was commissioned by the Civil Aviation Authority of Singapore (CAAS) and Workforce Singapore (WSG) to prepare and equip our aviation workforce with the essential skills for future roles. The Report offers comprehensive insights into the aviation workforce landscape and highlights industry megatrends that are reshaping job roles. It aims to

offer business and human resource leaders insights on the redesign of existing job roles and the critical and emerging skills to be developed. Additionally, it serves as a practical guide for individuals to explore career opportunities, understand skill requirements for new aviation roles, and access resources to bridge skill gaps.

The Report also embodies our unwavering commitment to empower both employers and workers throughout this exciting transformation journey. By forging a strong partnership among CAAS, WSG, aviation employers, the National Trades Union Congress and the Aerospace & Aviation Cluster of Unions, we are creating robust pathways for career advancement and bridging crucial skills gaps in this vibrant sector. We are deeply grateful to Ministry of Manpower, Ministry of Transport, Ministry of Education, SkillsFuture Singapore, the Institutes of Higher Learning and our consultant Ernst & Young for collaborating with us in this endeavour. Together, we can ensure Singapore's aviation sector continues to soar to greater heights, powered by a skilled and future-ready workforce.

Mr Han Kok Juan
Director-General,
Civil Aviation Authority
of Singapore



Ms Dilys Boey
Chief Executive,
Workforce Singapore

Contents

01 The OneAviation Workforce

- a. Navigating a Changing World [>05](#)
- b. Sector Workforce Size [>07](#)
- c. Sector Workforce Profiles [>08](#)

03 Taking Flight

- a. Progress under the Air Transport ITM 2025 [>26](#)
- b. Strengthening OneAviation Workforce Development [>28](#)

02 Jobs and Skills Transformation

- a. Key Megatrends [>15](#)
- b. Impact Assessment [>16](#)
- c. Future of Jobs and Skills [>17](#)
- d. Ground Handling Jobs Transformation [>18](#)
- e. Case Studies [>20](#)

04 Acknowledgements

- a. Acknowledgements [>33](#)

01 The OneAviation Workforce

- a. Navigating a Changing World
- b. Sector Workforce Size
- c. Sector Workforce Profiles

Navigating a Changing World



Strong traffic growth & intensifying competition for talent

Global passenger volumes are projected to double in the next two decades, with the Asia-Pacific region expected to drive over half of this growth¹.

Skilled manpower will continue to be a competitive advantage for the Changi air hub, and allow us to seize opportunities.

At the same time, competition for skilled manpower is intensifying among air hubs, with many growing air hubs willing to pay a premium for skilled aviation professionals.

It would be critical for the sector to strategise and execute plans and strategies as an ecosystem to attract, develop and retain our skilled workforce.



Long term capacity investments

To capture the growth opportunities in the Asia-Pacific region, Changi will see the construction of a fifth terminal and start of three-runway operations. In its first phase, Terminal 5 would be able to handle about 50 million passenger movements per year and is expected to be operational around the mid-2030s.

With the expected increase in passenger and cargo handling capacity and infrastructural footprint, we must also plan ahead for our OneAviation workforce to be equipped with the skills and technologies to deliver their best.



Changi Airport's Terminal 5 - Artist Impression

¹ Source: [IATA Global Outlook for Air Transport, Jun 5 2024](#)



Emerging and new areas of jobs and skills

Aviation is a sector that always seeks to be at the forefront of innovation. We constantly adopt new technologies to empower our workers to value-add further in their roles.

Over the next 5 years, the sector is investing significantly in several initiatives across Artificial Intelligence (AI), automation, and digitalisation.

These efforts could create new job roles and transform the skills required by our workforce.



Changing workforce demographics and preferences

Singapore has an ageing workforce. The proportion of our citizen population aged 65 years and above is rising, and at a faster pace compared to the last decade. By 2030, around 1 in 4 citizens (24 per cent) would be aged 65 and above².

At the same time, there are evolving workforce preferences, such as a growing emphasis on flexibility, well-being, and personal development.

Such trends have significant implications on employers and workers. As an ecosystem, we will need to transform our work and workplace to be more age-friendly, and reduce the physical demands of work. We will need to support employers to redesign and rethink new models of work within aviation's unique context, where the airport never sleeps, and operates 24/7. At the same time, we need to constantly reimagine and rebrand what we do as a OneAviation community, to continue to profile appealing and compelling careers to our future generations of aviation professionals.

In 2024, CAAS and WSG embarked on a manpower study for the aviation sector.

The study comprised 3 deliverables:



Establish the post-COVID-19 landscape of the OneAviation workforce



Identify and assess trends impacting jobs and skills across key sub-sectors



Recommend ways to strengthen workforce development

²Source: [National Population & Talent Division](#).

Sector Workforce Size

The OneAviation workforce is over 60,000 strong and growing. The main sub-sectors³ are:

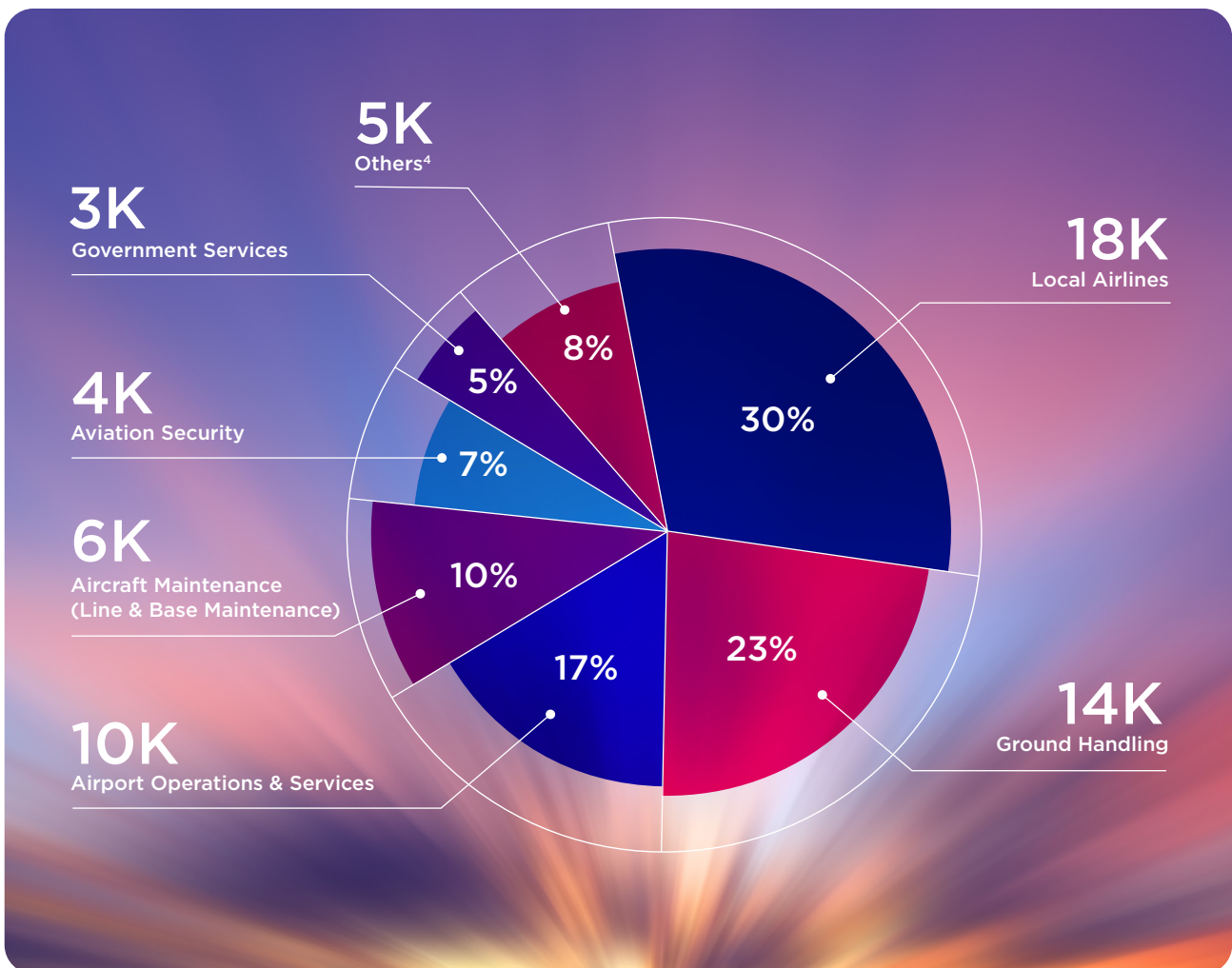

³ Workforce figures are rounded to the nearest thousand.

⁴ This includes various smaller workforce segments such as foreign passenger and freight airlines, and air express services.

Sector Workforce Profile:

Local Airlines⁵

The majority of the workforce in our local airlines are employed for the management of in-flight operations and service delivery such as in Pilot and Cabin Operations roles. There are also ground-based positions responsible for ensuring smooth flight operations and ground services, and corporate roles including revenue management, commercial, IT and HR.

The airlines' workforce has a strong Singapore core, and a median age of below 40 years old.

Key Operational Job Functions

- Pilot Operations
- Cabin Operations
- Flight Operations
- Ground Services

Examples of Job Titles:

Pilot, Cabin Crew, Flight Dispatcher, Operations Controller, Flight Controller



Cabin Crew

Singapore Airlines

⁵ These are commercial airlines holding a Singapore Air Operator Certificate such as Singapore Airlines Limited and Scoot Pte Ltd

Sector Workforce Profile:

Ground Handling

The ground handling sub-sector is a critical component of airport operations, employing a diverse and specialised workforce across three main functions: “Above-wing”, “Below-wing” and In-Flight Catering.

“Above-wing” roles focus on passenger facing services such as check-in and boarding assistance. “Below-wing” roles are responsible for managing complex and varied operations at the airside including baggage and cargo operations, aircraft marshalling and aircraft interior cleaning.

In-Flight Catering roles are responsible for preparing, packaging and the timely delivery of meals, beverages and supplies to aircraft in adherence to strict hygiene practices. The demographics within each job function differ. For example, the “Above-wing” workforce has a median age of below 40 years old, while the more experienced workforce in “Below-wing” and Inflight Catering have a median age of below 55 years old.

The ground handling sub-sector is investing heavily in technology and automation over the next few years, as technologies such as autonomous vehicles, robotics for baggage handling and the use of AI for manpower and asset optimisations mature. Employers will need to invest in training and upskilling their workforce in tandem to harness these technologies effectively.



Key Operational Job Functions

- Passenger Services
- Flight Operations
- Baggage Services
- Cargo Handling
- Ramp Services
- Load Control
- Technical Services
- Aero Laundry
- Technical Ramp Services
- In-flight Catering
- Aircraft Interior Cleaning
- Cabin Services
- Catering Prep
- Culinary
- Catering Technician

Examples of Job Titles:

Passenger Services Associate, Airline Relations Executive, Cargo Coordinator, Ramp Specialist, Sous Chef, Quality Assurance Supervisor

Customer Service Agent
dnata

Executive Sous Chef
SATS Ltd

Load Control Officer
SATS Ltd

Assistant Manager, ULD Cargo Operations
SATS Ltd

Sector Workforce Profile:

Aircraft Maintenance (Line & Base Maintenance)

Line maintenance professionals perform essential pre-flight inspections and time critical maintenance to ensure every aircraft is safe and ready for its next flight. Base maintenance professionals perform scheduled, comprehensive inspections, in-depth maintenance, and structural repairs on aircraft, which is vital in maintaining aircraft safety, reliability and operational readiness.

The sub-sector employs a strong Singapore core, with a highly skilled and competent workforce with an average of 20 years of experience.

Being highly specialised, the workforce in this sector undergoes rigorous training to attain the necessary qualifications and competencies to become certifying technicians or licensed aircraft engineers.

Key Operational Job Functions

- Aircraft Maintenance
- Aircraft Exterior Cleaning
- Cabin Maintenance
- Planning

Examples of Job Titles:

Certifying Technician, Ramp Specialist, Licensed Aircraft Maintenance Engineer, Assistant Foreman, Engineering Supervisor



Engineering Supervisor

SIA Engineering Company

Sector Workforce Profile:

Aviation Security

Aviation Security, or “AvSec” for short, maintains the safety and security of airports and aircraft. This includes duties such as screening passengers, baggage and cargo, monitoring surveillance, controlling access to restricted areas and responding to security incidents.

This sub-sector employs a strong Singapore core with a median age below 50 years old.

AvSec has traditionally relied on human judgement, presence and interaction to detect suspicious behaviour and respond to incidents in real time. However, the nature of work in aviation security is expected to change significantly in the coming years due to automation. Security personnel roles will evolve from hands-on tasks to more analytical roles such as monitoring AI systems, interpreting data and responding to alerts.

Key Operational Job Functions

- Auxiliary Police
- Security Officer

Examples of Job Titles:

Aviation Security Officer, Aviation Screening Officer, Auxiliary Police Officer, Commanding Officer, Duty Operations Supervisor

Auxiliary Police Officer

Certis Aviation Security



Sector Workforce Profile:

Airport Operations and Services

The Airport Operations and Services sub-sector encompasses a diverse range of job functions and disciplines providing essential services at the airport. Employers include Changi Airport Group, retail and food and beverage (F&B) establishments, cleaning and facility management companies, critical system vendors and many more, who work together to deliver the Changi experience. They range from local companies to foreign multinational firms.

Companies in labour-intensive segments such as in cleaning, F&B, and retail would need to continue leveraging technology to augment their workforce and optimise processes to improve productivity, yet retain the warm and positive service experiences many expect at Changi.

Key Operational Job Functions

- Passenger Services (Terminal)
- Baggage Services (Terminal)
- Airport Operator
- Travel Retail
- Facilities Management
- Cleaning and Waste Management
- Aviation Systems
- F&B and Related Services

Examples of Job Titles:

Duty Terminal Manager, Airport Emergency Services Firefighter, Facility Services Specialist, Systems Engineer, Senior Data Engineer, Beauty Ambassador, Retail Supervisor, Restaurant Manager

Airport Emergency Services Officer

Changi Airport Group



Other OneAviation Sub-Sectors

Beyond the 5 sub-sectors mentioned, there are other sub-sectors that contribute significantly to the aviation ecosystem, ensuring the safe, efficient, and secure operations at the air hub. They broadly fall within the following 3 clusters:

Air Traffic Control Officer

Civil Aviation Authority of Singapore



Government services

This includes (i) the Civil Aviation Authority of Singapore, which is the national air navigation services provider as well as aviation regulator; (ii) immigration officers from the Immigration and Checkpoints Authority managing border control and verifying travel documents; (iii) officials from Singapore Customs handling the inspection of goods and enforcement of trade laws; and (iv) airport police personnel from the Singapore Police Force tasked with screening and threat response.



Foreign Passenger Airlines and Freighter Airlines

This includes the branch offices and call centres of foreign passenger and cargo airlines that fly to and from Singapore. Foreign passenger and cargo airlines contribute to the vibrancy of our air hub by expanding our international connectivity and cargo capacity, strengthening our air hub's position in the global aviation network.



Air Express Services

A specialised arm of logistics that offers fully integrated, end-to-end delivery solutions, managing the entire logistics process including both the air and ground transportation. This enables the rapid, reliable movement of time-sensitive shipments across global networks from door-to-door which is critical in supporting just-in-time supply chains, e-commerce fulfilment, and international trade. The workforce comprises a diverse range of job functions, ranging from air crew and ground handling to cargo management.

Examples of Job Titles:

Air Traffic Control Officers, Air Traffic Control Support Officers, Aviation Safety Inspector, Flight Operations Inspector, Immigration Officer



02

Jobs and Skills Transformation

- a. Key Megatrends
- b. Impact Assessment
- c. Future of Jobs and Skills
- d. Ground Handling Jobs Transformation
- e. Case Studies

Key Megatrends

6 key technology and non-technology megatrends will shape the future of jobs and skills in the aviation workforce over the next 5 years

Technology Megatrends



Automation and Robotics:

The deployment of advanced technologies will transform manual and repetitive operations into streamlined automated processes. Some examples of automation likely to be deployed in the next few years include automated Passenger Loading Bridges (PLB), automated or autonomous aircraft pushback, and Autonomous Vehicles (AVs) for baggage and cargo transport at the airside.



Digitalisation:

Digitalisation has been a known trend for many years, but there has been an acceleration of adoption and greater integration of digital technologies with traditional processes and systems, enhancing efficiency and enabling real-time monitoring. Aviation professionals now use advanced digital resource deployment systems and digital asset tracking systems to assist them in their work, raising their productivity and situational awareness.



Data and Artificial Intelligence (AI):

With digitalisation, there is greater collection of data, enabling the sector to harness the full potential of AI. Gen AI, Agentic AI and Embodied AI are already being harnessed by aviation companies to optimise resource and asset allocation, improve service response to disruptions, and enhance the customer/passenger experience.

Non-Technology Megatrends



Changing Consumer Preferences:

A shift in demand towards personalised, seamless, and contactless experiences, prioritising health, safety, and sustainability. This megatrend drives the transition to digital services and flexible, eco-friendly practices.



Changing Workforce Preferences:

This includes an increased demand for flexible work arrangements, skills development and work-life balance. This megatrend encourages the adoption of remote models, investments in training for digital competencies and creation of supportive work environments.



Sustainability:

A growing demand for the adoption of fuel-efficient/alternative fuel aircraft, electric vehicles and carbon offsets, alongside operational changes such as the implementation of eco-friendly practices like waste management to reduce environment impact.

Impact Assessment

How then do these trends translate into new or transformed jobs and skills for the aviation workforce, over the next 5 years? An assessment scale was used to evaluate the impact on different profiles of workers, providing insights into anticipated changes across various job roles in the aviation industry.

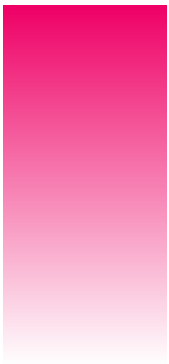

High degree of impact

Work processes may undergo **fundamental transformation** due to technological advancements and major industry trends.

Jobs may require **extensive redesign**. Job holders may require substantial reskilling/ upskilling support.



Medium degree of impact

Work processes may undergo **moderate changes** due to technological integration and industry megatrends.

Jobs would require **moderate redesign**. Job holders may shift towards higher value-adding tasks which require moderate reskilling/ upskilling support.



Low degree of impact

Work processes remain **largely unchanged**, with **minimal impact** by technology and industry megatrends.

Future of Jobs and Skills

Over the next 5 years, up to 30% of aviation jobs may experience redesign and transformation, defined as those jobs which would experience moderate to high impact from the identified industry megatrends. They will also create new and exciting career possibilities in the Singapore aviation sector.

Workers in these job roles must be supported with upskilling and reskilling opportunities, to acquire new competencies to capture emerging opportunities in the transformed aviation landscape. Many of these opportunities are in the ground handling sub-sector.



30% of the aviation workforce could experience job redesign in the next 5 years

Job roles performing manual-intensive routine work would experience a **high degree of change** in their job tasks, as technology advances would see adoption of assistive tools to augment manpower and reduce the manual-intensity of work, or possibly fully handle parts of these tasks. For example, manual baggage lifting can be made less physically taxing with roller belt conveyers, or possibly by eliminating heavy lifting altogether with robotic arms. Drivers operating tractors towing cargo and baggage at the airside could soon be remotely monitoring autonomous vehicles conducting these tasks from an office.

These jobs will evolve towards technology-focused responsibilities and higher value-adding activities. This shift necessitates future skills in:

System Operations and Maintenance:

Utilise advanced technologies to diagnose, troubleshoot and rectify system anomalies

Digital Documentation and Reporting:

Create and manage digital incident reporting

Remote Systems Management:

Manage digital systems and operations remotely

AI-Driven Risk Management:

Implement preventive measures based on AI-driven insights to mitigate risks and prevent safety incidents

Supervisory and management roles will need to leverage data analytics and AI insights from new technologies to drive operational improvements. This shift necessitates future skills in:

Data Analytics and Insights:

Interpret and analyse data to generate insights to improve operations

Digital Training Management:

Plan and deliver training on the use of new technologies

Digital Information Management:

Manage and organise digital information, ensuring it is accurately recorded on digital platforms

Technology Implementation Strategy:

Evaluate impact of technology and develop SOPs to manage its use

Ground Handling Jobs Transformation

The ground handling sub-sector is the second largest employment cluster within the aviation workforce with over 14,000 workers, and plays a crucial role in the success of the air hub. With significant investments in technology and workplace enhancement initiatives underway, the sub-sector is expected to see its workforce upgrading significantly over the next few years. More workers will be upskilled and reskilled, uplifting capabilities within the sub-sector and driving higher value-added services across the spectrum of ground handling services.

In particular, the use of automation and robotics can replace some of the physically demanding and manual tasks, creating a more worker-friendly and age-inclusive work environment. This shift enables workers to focus on higher value-added activities such as process and concept-of-operations improvements, remote monitoring, and oversight and exception handling. Such transformation will be critical in view of Singapore's ageing population and its progress as a Smart Nation.

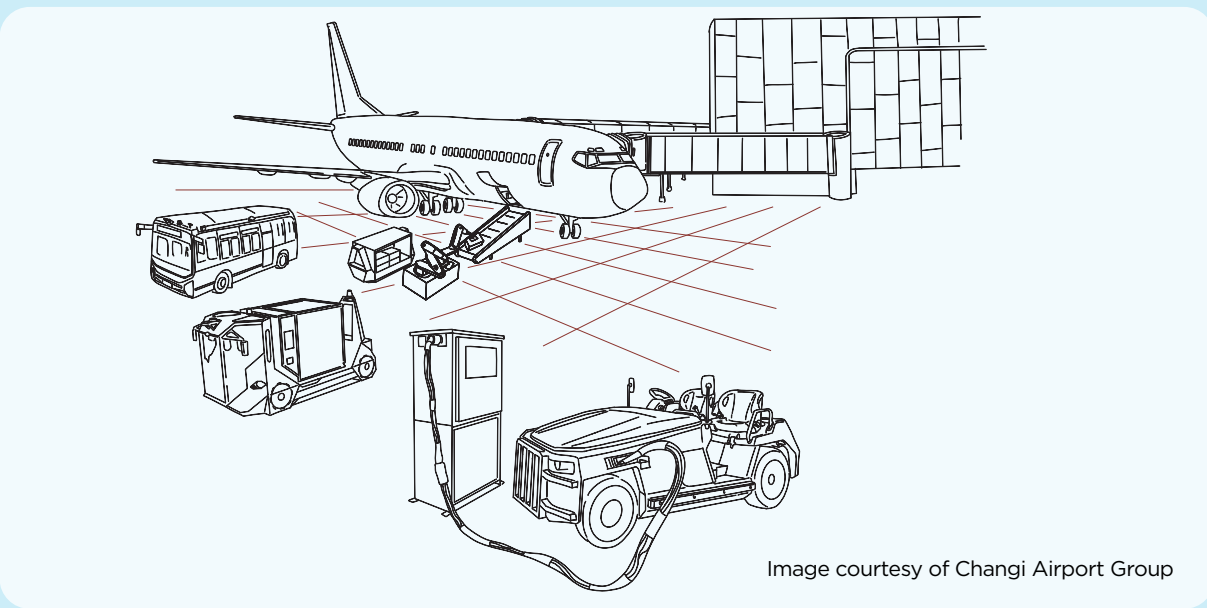
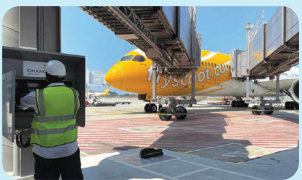
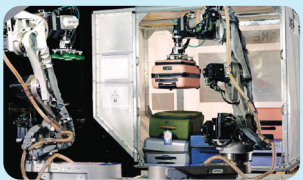

Image courtesy of Changi Airport Group



Automated Aerobridge Docking

The automated aerobridge docking system will allow remote docking of both aerobridges onto a wide-body aircraft simultaneously, improving productivity and operational efficiency.



Robotic Baggage Handling

Robotic baggage handlers can operate in the terminals and under rain and lightning conditions at the aircraft stands, enabling continuous operations and timely delivery of baggage for passengers.



Clean Energy Apron

From 2025, all new airside light vehicles, forklifts and tractors will be electric.

In the coming years, the airside electric vehicle charging network will triple to 300 points.

Terminal 5 will be able to support a fully electric airside fleet.

We deep dived into the specific ground handling functions, and assessed the changing nature of work and opportunities for its workforce. Some examples of job functions where we expect to experience a medium to high impact are shown below:

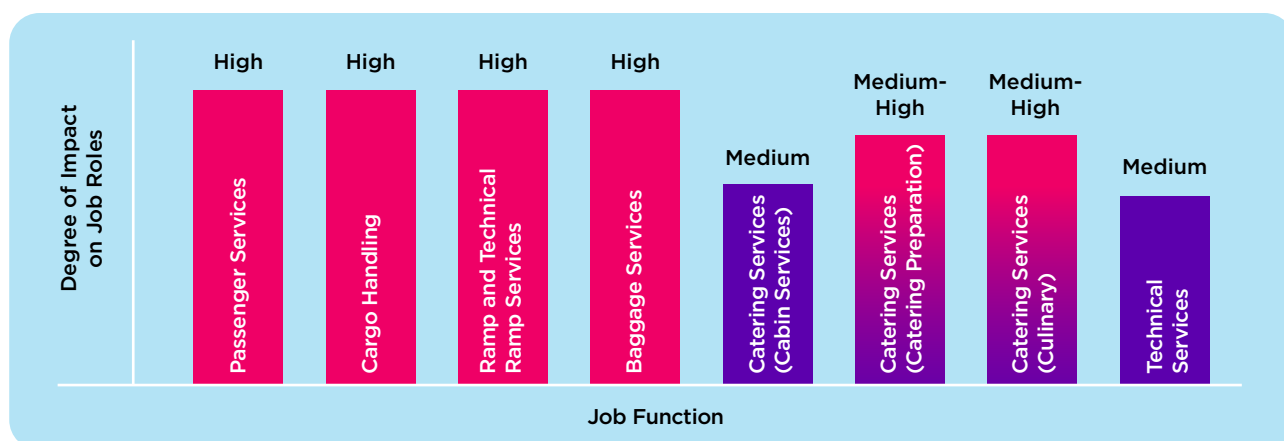

Baggage Services/ Cargo Handling/ Ramp and Technical Ramp Services

The increasing adoption of AVs will create demand for new fleet supervisory roles. These supervisors would remotely manage multiple AVs focusing on real-time monitoring of operational systems and implementing emergency response protocols.



Cargo Handling

Cargo Officer and Assistant roles would increasingly focus on complex tasks such as handling sensitive goods i.e., pharmaceutical and perishables, building up operational capabilities to be well-rounded and multi-skilled through cross deployment. This would require them to undergo training to support new company certifications such as the Center of Excellence for Independent Validators⁶ (CEIV).



Passenger Services

With the adoption of contactless and remote check-in technologies at the airport, the customer services agent role could be evolved to provide real-time assistance to passengers via digital platforms, and focus on exception handling for special cases such as passengers with special needs or unusual circumstances.



Technical Services

With the growing electrification of airport Ground Support Equipment (GSEs), there would be need for technicians to specialise in maintenance and management of electric vehicles, e.g. batteries systems, electric drivetrains, hydraulics and charging infrastructure.



Ramp and Technical Ramp Services

Technical Ramp and Ramp Officer roles may be cross-trained, allowing a centralised team to handle both Technical Ramp and Ramp tasks. This would enhance job value and improve workers' employability. Through multi-skilling, workers could also be cross-deployed, therefore boosting overall airside productivity.



In-flight Catering (Catering Preparation)

With the shifting of some frozen meal production overseas, there would be a need to build up supply chain management knowledge and skillsets among catering professionals e.g. inventory management, quality control, logistics coordination, and delivery optimisation. Workers in this job function would also need to be trained in downstream waste segregation techniques, so as to comply with environmental regulations and implement effective waste reduction strategies.

⁶ The CEIV certification program was created by International Air Transport Association (IATA) to help organisations throughout the air cargo supply chain get on the right track to achieve operational excellence in the handling and transportation of special cargo.

Case Studies

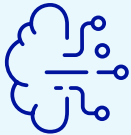

Technology adoption is rarely just a “plug-and-play”. It changes the nature of work as processes and workflows often undergo redesign as the man-machine-method interface is optimised.



Managing the impact on workers, and supporting them as they upskill and familiarise with new processes and technologies, must be anticipated and planned for in advance.



Here are some examples of how the sector is harnessing technology and how it uplifts jobs, creates more impactful and meaningful work, and drives greater productivity and value-added contributions by workers to their companies.

Case Study 01

Leveraging AI to enhance resource allocation and optimisation for baggage towing operations

Previous State: Manpower allocation on a flight-based approach

Baggage operators are typically assigned by flights. They wait for the progressive unloading of baggage and tow them to the baggage handling area, until all bags from the flight are processed.

This can lead to unproductive waiting time for the operator if unloading is delayed for any reason.

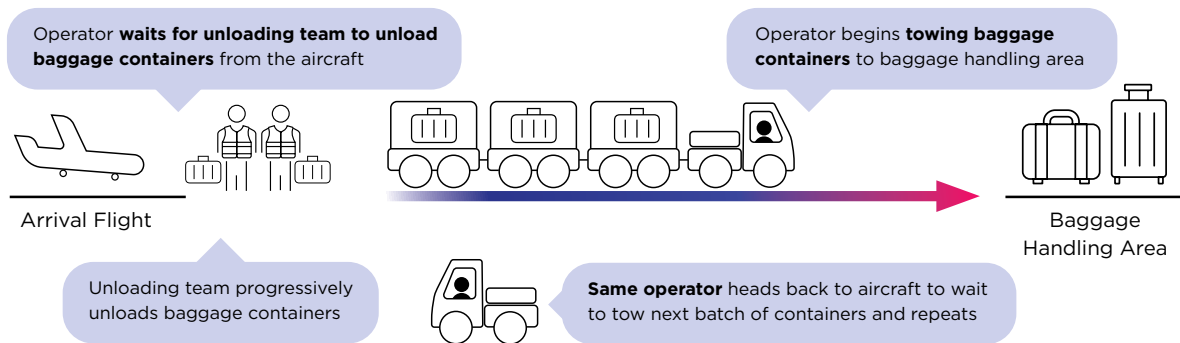

Current State: Manpower allocation on a task-based approach

AI enables the assignment of drivers by tasks, each allocated independently of each other, adjusting dynamically to disruptions and delays.

Drivers now only arrive at a flight when the baggage is ready for towing, reducing wait time, and raising productivity and service performance.

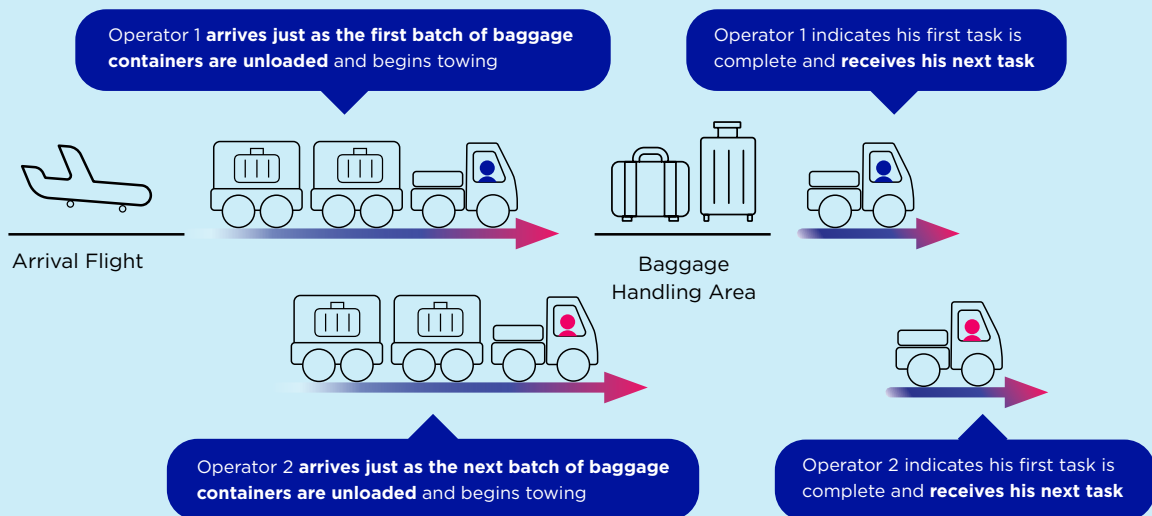

Case Study 02

Deployment of AVs for point-to-point driving tasks to reduce human fatigue and increase handling capacity

Current State: Significant man-hours spent on the road transferring baggage and cargo from point-to-point at the airside

Operators can spend more than half their time moving from point to point e.g. from aircraft stand to cargo terminal, or from baggage handling area to aircraft stand.

Long driving periods can increase human fatigue and reduce effective productivity.

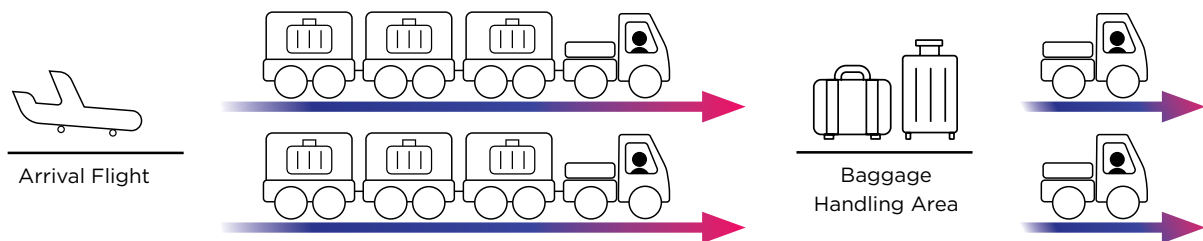

Baggage towing operations are manual; with drivers operating tractors towing several baggage carts

Future State (Advanced trials on-going): Deployment of AVs for point-to-point transport operations

AVs would relieve drivers of the time-consuming point-to-point transport operations, allowing operators to focus on conducting last-mile safety-critical equipment operations within the aircraft stand.

New roles would be created in conducting remote supervision and monitoring of fleets of AVs, and exception management.

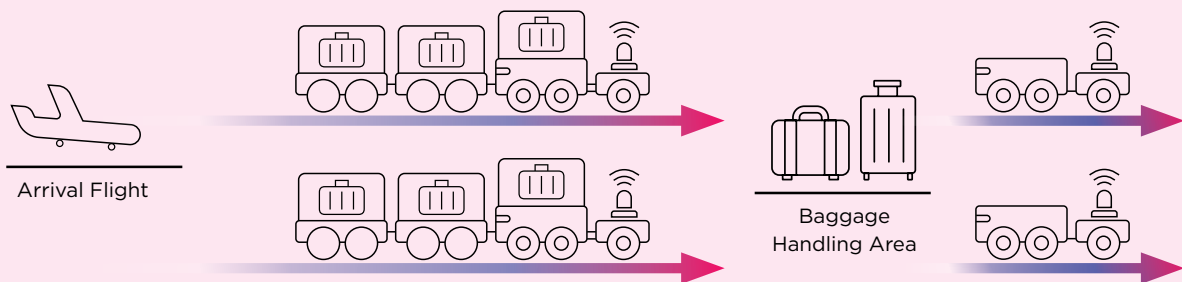

Remote Supervisor oversees fleet operations of AVs and manages exceptions and troubleshooting

Baggage towing operations are automated with AVs

Case Study 03

Leveraging robotics to reduce human error and improve oversight in inspections

Current State: Manpower needed for manual security operations at gatehold rooms

Security Officers manually perform security sweeps of gatehold rooms pre-flight to ensure no items are left behind, especially prohibited items.

This requires them to report earlier before a flight to conduct the sweep before the gatehold room can be open for the next flight's boarding.

Such manual inspections would possibly be prone to risk of human error and oversight.

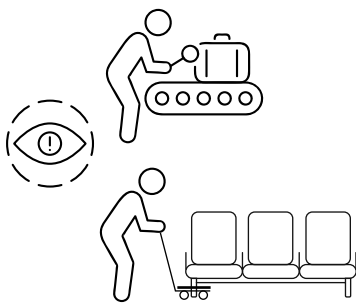

Officers **manually perform security sweeps** and activate machines

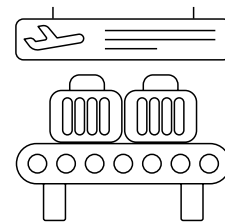

Future State (Advanced trials on-going): Deployment of robotic rover to automate and augment security sweeps of gatehold rooms

Robotic rover with AI functionalities may conduct security sweeps.

Officers can focus on monitoring robotic inspections, activation of machines, reporting and exception handling and trouble-shooting.

AI-driven inspections will enhance precision and reliability, leveraging machine learning to progressively identify hotspots and improve overall security effectiveness

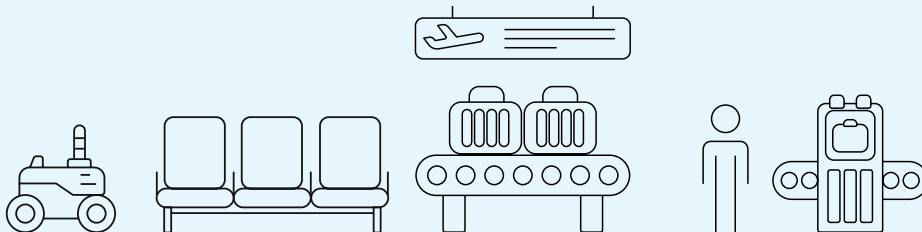

Robotic rover will perform security sweeps, using AI to quickly detect any items left behind

Officers will monitor robotic inspections, focusing on activating machines, reporting and handling exceptional cases, and first-line troubleshooting for any issues encountered by the robotic rover

Case Study 04

Green transition for airside vehicles and GSEs will drive new skills requirements in vehicle maintenance and repair

Current State: Majority of airside vehicles are operating on internal combustion engines, with a small electric fleet

The maintenance regime for internal combustion engines (ICE) and electric vehicles differ; there are different toolings, repair frequencies and infrastructure needed.

Maintenance for ICE vehicles is largely done on a scheduled basis or reactively when faults occur.

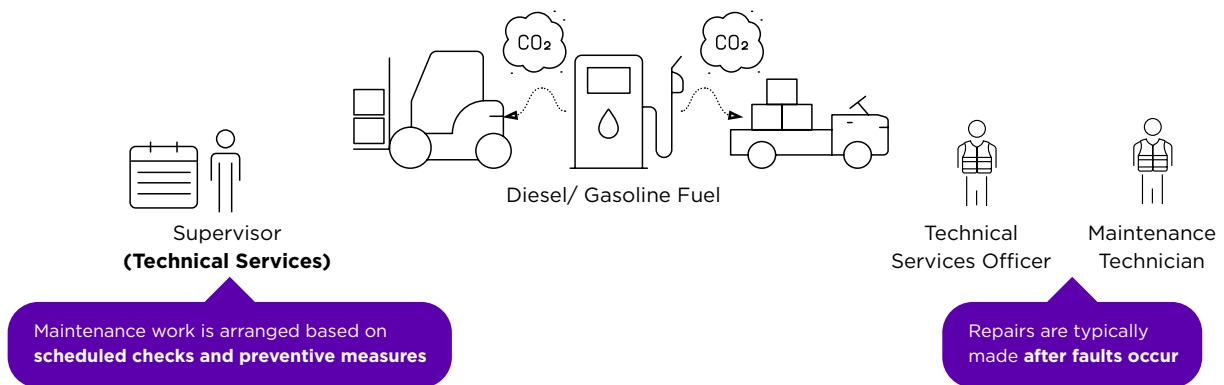

Future State: All airside vehicles are expected to run on cleaner energy by 2040

With increasing numbers of vehicles running on cleaner energy, technical services crew have to balance between the different maintenance demands of both ICE, electric, and in future, even hydrogen powered vehicles.

Electric vehicles maintenance knowledge and skills would include battery management, handling electric drivetrains, hydraulics and charging infrastructure.

Technicians can also leverage computerised systems in electric vehicles for predictive and just-in-time maintenance.

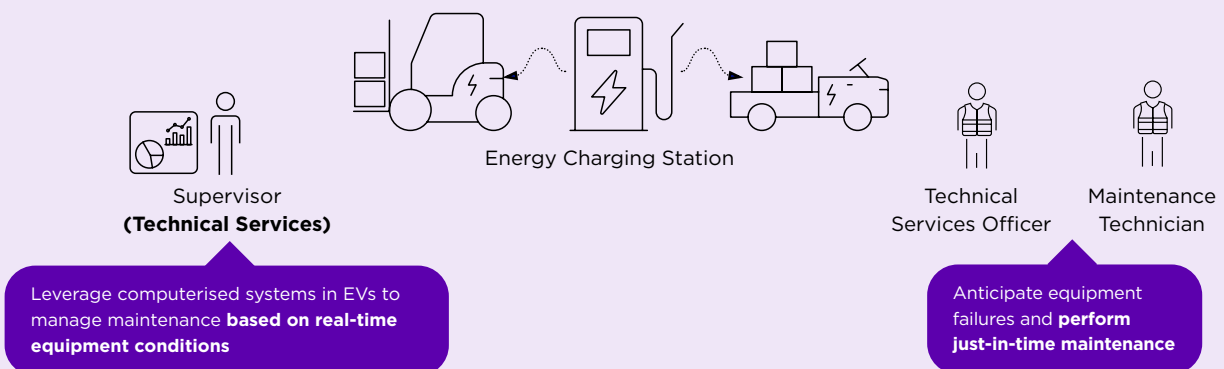

03

Taking Flight

- a. Progress under the Air Transport ITM 2025
- b. Strengthening OneAviation Workforce Development

Progress under the Air Transport ITM 2025

In August 2023, CAAS launched the Air Transport Industry Transformation Map⁷ 2025 (ITM) which laid out strategies to position the Singapore air hub for growth as the sector poised itself for full recovery from the COVID-19 pandemic. The ITM drove alignment among employers, workers, and the government to build a strong ecosystem as a competitive advantage for the Singapore air hub.

One of the ITM's four strategies was to "Develop a Future-Ready and Resilient Workforce to secure the next bound of growth for the air hub". CAAS would work with the industry and unions to enhance the capabilities of our workforce and equip them with the knowledge and skillsets to seize new opportunities and adapt to disruptions.

Over the last two years, the sector has made strides in:



Creating quality jobs for Singaporeans

Key employers in the sector have set up Company Training Committees (CTCs) with their unions, and are partnering closely to support workers' wage competitiveness, skills upgrading, and job redesign.

- In August 2024, NTUC Secretary-General Mr Ng Chee Meng announced the first pilot project⁸ between an aviation company and NTUC to improve jobs and make them more attractive to Singaporeans. With the support of the Air Transport Executive Staff Union (AESU) and the SATS Workers' Union (SATSWU), SATS leveraged the NTUC CTC Grant to transform jobs in passenger services, cargo and apron operations.
- In October 2022, CAAS, in partnership with NTUC and NTUC's Employment and Employability Institute (e2i), also launched the OneAviation Careers Hub, a one-stop online aviation resource portal providing end-to-end job facilitation, career and training advisory and counselling, and recruitment services. Since its launch, the initiative has assisted over 3,500 jobseekers and helped more than 1,500 individuals secure jobs in the sector.

OneAviation Careers Hub has:



assisted over
3,500
jobseekers



helped more than
1,500
individuals secure jobs

WSG's Career Conversion Programme (CCPs) has also helped employers broaden their talent pool by reskilling mid-career new hires or existing employees into growth job roles with good, longer-term prospects. As of 2024, over 4,500 individuals have benefitted from the CCPs and gained new competencies that prepared them for diverse roles across airport operations, airline management, ground handling, and air cargo.

⁷ Source: CAAS

⁸ Source: NTUC



Improving worker productivity and alleviating physical stress through technologies and automation

Through COVID-19, the sector persevered with technology trials and adoption, which helped the sector as it emerged out of COVID-19 to drive greater productivity and service excellence. These efforts have intensified and several are on the cusp of live deployment, such as Autonomous Vehicles for baggage point-to-point transport.

Ground handlers have also deployed assistive conveyer beltloaders that can be extended into aircraft bellyholds to reduce the manual intensity of baggage loading and unloading for baggage handlers.

Many such efforts were catalysed with supporting grants from the CAAS Aviation Development Fund as well as the NTUC CTC Grant.



Building a cohesive OneAviation community

The tripartite community has worked together to drive workforce cohesion and well-being.

- In February 2025, then Minister for Transport Mr Chee Hong Tat announced at the Changi Airport's Annual Airport Celebration that Changi Airport would be making further enhancements to the airside working environment, where aviation workers could look forward to expanded rest areas, a second airside café, and better lighting and natural ventilation in restrooms.
- With these improvements, all airside workers will be within a 10-minute walk or short drive from an air-conditioned staff lounge or café.
- Changi Airport is also investing efforts into testing new ways to lower the ambient temperature in the baggage handling areas. Tripartite partners will continue to seek regular feedback on enhancing the airport working environment, as well as drive future efforts to support worker well-being.



Inaugural Aerospace and Aviation Symposium in 2024 (Credit: NTUC)

Strengthening OneAviation Workforce Development

The findings of the Jobs Transformation Report have been instrumental in helping us identify new and necessary areas of development, sharpen our strategies to support manpower planning for the sector, and uplift our workforce as we transform over the next decade. We will:



A **Deepen industry-education partnerships** to equip Singaporeans with future skills and capabilities and promote aviation careers.



B **Accelerate ecosystem-level investments in technology and Research & Development (R&D)** to assist workers and raise labour productivity.

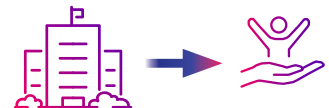

C **Provide stronger and more targeted support** to companies to transform jobs and better support workers.



Visit to Temasek Polytechnic training facilities by Senior Minister of State for Transport and National Development, Ms Sun Xueling (Credit: MOT)

Deepen industry-education partnerships

A robust and future-ready pipeline of aviation talent would be critical to meet our workforce needs and to power the growth of our air hub. We will deepen industry-education partnerships to equip Singaporeans with future skills and capabilities, and promote aviation careers.

Our local Institutes of Higher Learning (IHLs) run several specialised aerospace and aviation management programmes, which produce many graduates annually with skills tailored for the aviation sector. CAAS' training arm, the Singapore Aviation Academy also contributes significantly to supporting in-sector professionals upgrade and stay future-ready.

As the sector continues to grow and create new jobs, there is more we can do to tighten the industry-education nexus and ensure that knowledge and skills imparted in schools are future-proof and pertinent when students graduate and secure employment in the sector. Possible ways to do so include creating more work-study options at the tertiary level, as well as modular specialisations across more programmes in our IHLs, including those in Business Management and Administration, Engineering, Computer Science, Social Sciences and Supply Chain programmes.

Many mid-career professionals may also have interest in joining the sector, but are uncertain about the skills needed or the pathways available for them to succeed. For such individuals, we aim to curate clear pathways in partnership with key industry employers, in conjunction with mid-career courses and training at our IHLs.

Aviation sector employers, IHLs and training providers will work closely in 3 ways:

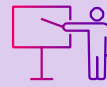

Ensure relevance of training programmes:

As an ecosystem, identify evolving training needs, develop curriculum, and provide structured internships and in-house training to students and workers;



Expand educational pathways:

Develop and expand course offerings in aviation across education institutions through new specialisation tracks in Pre-Employment Training (PET) programmes, targeted Continuing Education and Training (CET) programmes for mid-career transitions, and enhancing training capabilities and infrastructure; and



Enhance awareness of career opportunities:

Showcase diverse career opportunities across the entire aviation sector, in conventional and emerging areas, for students and mid-career individuals through career fairs, structured career guidance services and scholarship programmes.

Accelerate ecosystem-level investments in technology and R&D

The Singapore aviation sector has long invested in new technologies and automation to enhance service excellence, increase labour productivity, and improve cost-effectiveness. Over the next 5 years, enterprises across the sub-sectors in aviation have robust plans to trial, deploy, and scale-up technologies to optimise their processes and resource deployment.

There are also ecosystem-level initiatives in play. For example, the introduction of autonomous baggage tractors impacts not just one or two enterprises, but the entire airside ecosystem, from the ground handlers, to the airport operator, to the aviation safety regulator, workers and unions.

To secure the future of our air hub, including ensuring our jobs stay meaningful and attractive to future generations, the sector will work closely together to accelerate such transformational ecosystem-level investments in technology and R&D, so as to unlock greater synergies and productivity gains across the air hub.

Such projects would include adoption of autonomous airside vehicles and robotics solutions, leveraging digital technology and AI to automate complex tasks, and using real-time data driven insights. These initiatives will support improved labour output and service quality yet operating in a safe manner.

CAAS is committed to support such efforts in partnership with stakeholders. To expand mindshare and harness global innovation capacity to unlock solutions for airport and airspace challenges, CAAS has also in the past two years established robust platforms to drive international collaboration in aviation research, with the establishment of the International Centre of Aviation Innovation (ICAI), the International Aviation Lab (IAL) and International Avionics Lab.

In March 2025, CAAS announced a commitment of \$1 billion over the next five years to catalyse action and partnership in four key areas, including in Technology & Innovation⁹.



CAAS will be initiating the development of a multi-year technology roadmap for the sector, guided by the inputs from industry, unions, and the research community.

This will help provide direction for the trial and implementation of emerging technology, while translating research and development into operational capabilities that can be deployed across the aviation ecosystem.

⁹ Other focus areas include Connectivity, Manpower and Infrastructure. [Source: MOT](#)

Provide stronger and more targeted support to companies to transform jobs and better support workers

As processes and tools evolve from adoption of technologies and solutions, we must place equal emphasis on supporting our workers through the transition, both in terms of skills and mindsets, as well as harnessing their firsthand experiences to enhance how these technologies are integrated into their work. The NTUC CTCs are an important platform to drive this iterative process and change management with employers and workers.

In addition to CTCs, individuals and companies may tap on various NTUC and Singapore Government grants:

- Eligible individuals could tap on schemes such as the [SkillsFuture Credit](#), [SkillsFuture Level-Up Programme](#), [SkillsFuture Career Transition Programme](#) and [Workfare Skills Support](#) to receive training support.
 - Individuals could also elevate their career through Career Planning and upskilling recommendations through WSG's [Polaris](#) and CareersFinder by MyCareersFuture.
 - Companies could tap on schemes such as [Career Conversion Programme](#) (CCP), [Support for Job Redesign under the Productivity Solutions Grant \(PSG-JR\)](#), [NTUC CTC Grant](#), [Enterprise Development Grant](#), and [SkillsFuture Enterprise Credit](#) (SFEC) to offset the cost of reskilling and job redesign.
 - Companies could also participate in WSG's Career Health SG initiative to identify skills gaps in their workforce and understand the competencies needed for workforce development. This allows companies to adopt a skills-first hiring approach to better attract and tap into broader talent pools. With a better understanding of the skills gaps, companies can also equip Line Managers and HR Managers with competencies in developing structured career development plans and conducting meaningful career conversations, ultimately improving employee retention.
- Starting in 2026, WSG will also be consolidating existing workforce transformation schemes under the SkillsFuture Workforce Development Grant to simplify the application process and increase support for job redesign, exceeding the current funding levels available through the PSG-JR.

At the sectoral level, CAAS and WSG will complement these initiatives to strengthen support to the aviation ecosystem employers and workers.



CAAS will establish a \$200 million OneAviation Manpower Fund to support the sector's workforce transformation. The Fund will support initiatives by unions, aviation companies and education providers to better attract, develop and retain our OneAviation workers. The \$200 million is part of the \$1 billion earlier announced by CAAS in March 2025 to support Singapore's air hub development.



WSG will launch an Aviation Sector Job Redesign Playbook to support companies in identifying and implementing job redesign opportunities effectively. This playbook will provide a step-by-step guide, complete with practical tools, frameworks and action plans to assist employers and professionals in navigating their job transformation journey.

04

Acknowledgements

Acknowledgements

CAAS and WSG would like to extend our deepest appreciation to all individuals, agencies, and organisations who have contributed actively to the study and the preparation of this Report. They include the:

Singapore Aviation Sector Tripartite Committee (SASTC) comprising CEO and management-level representatives from Changi Airport Group, Civil Aviation Authority of Singapore, dnata, Immigration and Checkpoints Authority, Jetstar Asia, Ministry of Manpower, Ministry of Transport, National Trades Union Congress, Aerospace & Aviation Cluster of Unions, SAAA@SG, SATS, Scoot, SIA Engineering Company, Singapore Airlines and Workforce Singapore.

Aviation Tripartite Manpower Planning Working Group (TWG) comprising HR leaders and representatives from the Changi Airport Group, Civil Aviation Authority of Singapore, dnata, Employment and Employability Institute, Immigration and Checkpoints Authority, Jetstar Asia, Ministry of Manpower, Ministry of Transport, National Trades Union Congress, SATS, Scoot, SIA Engineering Company, Singapore Airlines, and Workforce Singapore.

NTUC and the Aerospace & Aviation (A&A) Cluster of Unions comprising the Air Transport Executive Staff Union (AESU), Amalgamated Union of Public Employees (AUPE), dnata Singapore Staff Union (DSSU), Scoot Staff Union (STSU), SATS Workers' Union (SATSWU), SIA Engineering Company Engineers and Executives Union (SEEU), Singapore Airlines Staff Union (SIASU), Singapore Industrial & Services Employees' Union (SISEU), Singapore Manual & Mercantile Workers' Union (SMMWU), and the ST Engineering Staff Union (STESU).

Air Transport Sectoral Coordination Team (SCT) comprising representatives from IHLs with air transport programmes/courses, namely the Institute of Technical Education, Nanyang Polytechnic, Ngee Ann Polytechnic, Republic Polytechnic, Singapore Institute of Technology, Singapore Polytechnic, and Temasek Polytechnic.

In addition, we would also like to extend our thanks to the following industry, education, and government partners whom we also consulted extensively for the study:

Industry Partners

- Certis Group
- DHL
- FedEx
- United Parcel Service
- Changi Airport Group's concessionaires, vendors, and subcontractors, including Lotte Duty Free, Shilla Duty Free Singapore, and many others

Institutes of Higher Learning

- Singapore University of Social Sciences
- Singapore University of Technology and Design

Government Agencies

- Singapore Customs
- Singapore Police Force
- SkillsFuture Singapore

Our sincere thanks also goes out to Ernst & Young, our consultants who partnered us through this journey of discovery and learning.

© 2025 Civil Aviation Authority of Singapore

All rights reserved. No part of this publication may be reproduced or redistributed without the prior written permission of the Civil Aviation Authority of Singapore. You may, however, download for your own non-commercial off-line viewing.