



MINISTRY OF EDUCATION, SINGAPORE
 in collaboration with
 CAMBRIDGE INTERNATIONAL EDUCATION
 General Certificate of Education Advanced Level

CANDIDATE
 NAME

--

CENTRE
 NUMBER

S				
---	--	--	--	--

INDEX
 NUMBER

--	--	--	--

* 0 1 2 3 4 5 6 7 8 9 *

PHYSICS

9814/01

Paper 1

For examination from 2026

SPECIMEN PAPER

3 hours

You must answer on the question paper.

No additional materials are needed.

INSTRUCTIONS

- Section A: answer **all** questions.
- Section B: answer **two** questions.
- Use a black or dark blue pen. You may use an HB pencil for any diagrams or graphs.
- Write your name, centre number and index number in the boxes at the top of the page.
- Write your answer to each question in the space provided.
- Do **not** use an erasable pen. Do **not** use correction fluid or tape.
- Do **not** write on any bar codes.
- You may use an approved calculator.

INFORMATION

- The total mark for this paper is 100.
- The number of marks for each question or part question is shown in brackets [].

This document has **32** pages. Any blank pages are indicated.



Singapore Examinations and Assessment Board



CAMBRIDGE
 International Education

Data

speed of light in free space	$c = 3.00 \times 10^8 \text{ m s}^{-1}$
permeability of free space	$\mu_0 = 4\pi \times 10^{-7} \text{ H m}^{-1}$
permittivity of free space	$\epsilon_0 = 8.85 \times 10^{-12} \text{ F m}^{-1}$
	$(\frac{1}{4\pi\epsilon_0} = 8.99 \times 10^9 \text{ m F}^{-1})$
elementary charge	$e = 1.60 \times 10^{-19} \text{ C}$
Planck constant	$h = 6.63 \times 10^{-34} \text{ J s}$
unified atomic mass constant	$u = 1.66 \times 10^{-27} \text{ kg}$
rest mass of electron	$m_e = 9.11 \times 10^{-31} \text{ kg}$
rest mass of proton	$m_p = 1.67 \times 10^{-27} \text{ kg}$
molar gas constant	$R = 8.31 \text{ J K}^{-1} \text{ mol}^{-1}$
Avogadro constant	$N_A = 6.02 \times 10^{23} \text{ mol}^{-1}$
Boltzmann constant	$k = 1.38 \times 10^{-23} \text{ J K}^{-1}$
gravitational constant	$G = 6.67 \times 10^{-11} \text{ N m}^2 \text{ kg}^{-2}$
acceleration of free fall	$g = 9.81 \text{ m s}^{-2}$

Formulae

uniformly accelerated motion	$s = ut + \frac{1}{2}at^2$	work done on / by a gas	$W = p\Delta V$
	$v^2 = u^2 + 2as$	pressure	$p = \frac{F}{A}$
moment of inertia of rod through one end	$I = \frac{1}{3}ML^2$	gravitational potential	$\phi = -\frac{GM}{r}$
moment of inertia of hollow cylinder through axis	$I = \frac{1}{2}M(r_1^2 + r_2^2)$	temperature	$T/\text{K} = T/^\circ\text{C} + 273.15$
moment of inertia of solid sphere through centre	$I = \frac{2}{5}MR^2$	pressure of an ideal gas	$p = \frac{1}{3} \frac{Nm}{V} \langle c^2 \rangle$
moment of inertia of hollow sphere through centre	$I = \frac{2}{3}MR^2$	mean translational kinetic energy of an ideal gas particle	$E = \frac{3}{2}kT$

displacement of particle in s.h.m.	$x = x_0 \sin \omega t$	magnetic flux density due to a long straight wire	$B = \frac{\mu_0 I}{2\pi d}$
velocity of particle in s.h.m.	$v = v_0 \cos \omega t$ $= \pm \omega \sqrt{(x_0^2 - x^2)}$	magnetic flux density due to a flat circular coil	$B = \frac{\mu_0 NI}{2r}$
electric current	$I = nAvq$	magnetic flux density due to a long solenoid	$B = \mu_0 nI$
resistors in series	$R = R_1 + R_2 + \dots$	energy in an inductor	$U = \frac{1}{2} LI^2$
resistors in parallel	$\frac{1}{R} = \frac{1}{R_1} + \frac{1}{R_2} + \dots$	RL series circuits	$\tau = \frac{L}{R}$
capacitors in series	$\frac{1}{C} = \frac{1}{C_1} + \frac{1}{C_2} + \dots$	RLC series circuits (underdamped)	$\omega = \sqrt{\frac{1}{LC} - \frac{R^2}{4L^2}}$
capacitors in parallel	$C = C_1 + C_2 + \dots$	energy states for quantum particle in a box	$E_n = \frac{h^2}{8mL^2} n^2$
energy in a capacitor	$U = \frac{1}{2} QV$ $= \frac{1}{2} \frac{Q^2}{C}$ $= \frac{1}{2} CV^2$	radioactive decay	$x = x_0 e^{-\lambda t}$
charging a capacitor	$Q = Q_0 \left[1 - e^{-\frac{t}{\tau}} \right]$	radioactive decay constant	$\lambda = \frac{\ln 2}{t_{\frac{1}{2}}}$
discharging a capacitor	$Q = Q_0 e^{-\frac{t}{\tau}}$	Lorentz factor	$\gamma = \frac{1}{\sqrt{1 - \left(\frac{v}{c}\right)^2}}$
RC time constant	$\tau = RC$	length contraction	$L = \frac{L_0}{\gamma}$
electric potential	$V = \frac{Q}{4\pi\epsilon_0 r}$	time dilation	$T = \gamma T_0$
electric field strength due to a long straight wire	$E = \frac{\lambda}{2\pi\epsilon_0 r}$	Lorentz transformation equations (1 dimension)	$x' = \gamma(x - vt)$ $t' = \gamma \left(t - \frac{vx}{c^2} \right)$
electric field strength due to a large sheet	$E = \frac{\sigma}{2\epsilon_0}$	velocity addition	$u' = \frac{(u - v)}{\left(1 - \frac{uv}{c^2} \right)}$
alternating current/voltage	$x = x_0 \sin \omega t$	relativistic energy-momentum relation	$E^2 = (pc)^2 + (mc^2)^2$

Section A

Answer **all** questions in this section.

You are advised to spend about 1 hour 50 minutes on this section.

- 1 Two perfectly elastic balls, A and B, are held above the ground at a height h , such that h is much greater than the diameter of each ball. The balls are almost touching, with ball A directly above ball B.

The balls are released simultaneously. Ball A rebounds to a maximum height H above the ground.

- (a) Sketch a labelled diagram to show the velocities of the balls relative to the ground just before they collide with each other.

Hence show that when the balls collide with each other, they do so with relative velocity $v_{\text{rel}} = \sqrt{8gh}$.

[3]

- (b) The mass of the lower ball m_B is greater than or equal to the mass of the upper ball m_A so that:

$$\frac{m_B}{m_A} = n \quad \text{and} \quad n \geq 1.$$

Determine an expression for the velocity of the centre of mass frame v_{CoM} relative to the ground immediately before the two balls collide.

[2]

(c) (i) Determine an expression for the ratio of the rebound height H to the drop height h .

[3]

(ii) Deduce the maximum value of $\frac{H}{h}$ for $n \geq 1$.

maximum value of $\frac{H}{h} = \dots\dots\dots$ [2]

[Total: 10]

- 2 A consequence of special relativity is that observers in different inertial reference frames disagree on the lengths of objects and the times between events.

(a) State what is meant by an inertial observer.

.....
 [1]

(b) An inertial reference frame (x, y, z, t) has Earth as its origin.

Ignore the rotational motion of Earth as negligible on the length scale of interest.

In this reference frame, the star Proxima Centauri is a distance of 4.25 light years (ly) along the positive x -axis, as shown in Figure 2.1.

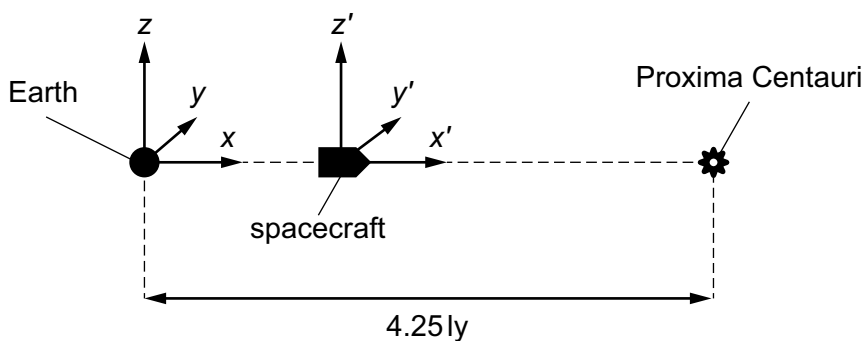

Figure 2.1

A spacecraft leaves Earth at $t = 0$ and travels directly to Proxima Centauri at a speed of $\frac{c}{2}$.

Assume that there is negligible relative motion between Earth and Proxima Centauri.

The origin of an inertial reference frame (x', y', z', t') moving with the spacecraft coincides with the origin of the Earth's reference frame at the moment the spacecraft leaves the Earth.

- (i) Write down the x and t coordinates of the spacecraft in Earth's reference frame at the moment of departure from Earth and at the moment of arrival at Proxima Centauri.

Use units of light years (ly) for x and years (yr) for t . In these units, $c = 1$.

x at departure = ly

t at departure = yr

x at arrival = ly

t at arrival = yr

[3]

- (ii) Use the Lorentz transformation equations to write down the x' and t' coordinates of the spacecraft at the moment of departure from Earth and at the moment of arrival at Proxima Centauri.

Use units of light years (ly) for x' and years (yr) for t' . In these units, $c = 1$.

x' at departure = ly

t' at departure = yr

x' at arrival = ly

t' at arrival = yr

[4]

- (iii) Using your answer in **2(b)(ii)** or otherwise, calculate the distance from Earth to Proxima Centauri in the (x', y', z', t') frame.

distance = ly [1]

- (iv) The spacecraft returns immediately to Earth at the same speed of $\frac{c}{2}$.

Explain why, for an inertial observer onboard the spacecraft, this journey could be considered a form of time travel.

Support your explanation with calculations.

.....
.....
.....

[3]

[Total: 12]

3 Some vacuum pressure gauges operate by measuring the number density of gas molecules. Such a gauge is calibrated for use in a system containing air at 300 K.

(a) Show that, for an ideal gas at a given constant temperature, the pressure is directly proportional to the number density of the molecules.

Any equations required may be quoted without proof.

[2]

(b) A research student connects the gauge to a vacuum system containing hydrogen at 50 K.

The student is surprised to obtain a pressure reading that, from other evidence, is clearly incorrect.

Derive the correction factor that the student should have applied to the gauge readings when used in the hydrogen system.

Assume that both air and hydrogen behave as ideal gases.

[3]

[Total: 5]

- 4 (a) State the principle of superposition of waves.

.....

.....

..... [2]

- (b) Figure 4.1 illustrates a plane wave of wavelength λ incident normally on three identical, narrow, parallel slits S_1 , S_2 and S_3 in a screen, with adjacent slits being separated by a distance d .

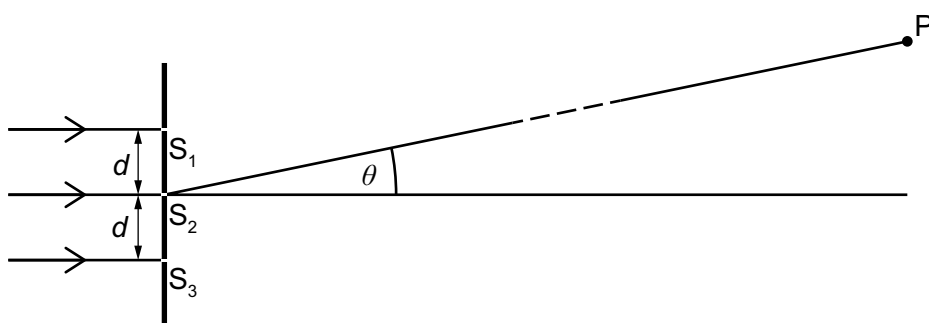

Figure 4.1

Point P is a very long way from the screen.

By applying the principle of superposition, show that the conditions for maximum and zero intensity at P are:

$$d \sin \theta = 0, \lambda, 2\lambda, 3\lambda, \dots \quad (\text{maximum intensity})$$

$$d \sin \theta = \frac{\lambda}{3}, \frac{2\lambda}{3}, \frac{4\lambda}{3}, \frac{5\lambda}{3}, \frac{7\lambda}{3}, \frac{8\lambda}{3}, \dots \quad (\text{zero intensity}).$$

You may wish to use the trigonometric relationship shown.

$$\sin A + \sin(A + B) + \sin(A + 2B) = \frac{\sin\left(\frac{3B}{2}\right) \sin(A + B)}{\sin\left(\frac{B}{2}\right)}$$

[4]

- (c) (i) Use the principle of superposition and the information in **4(b)** to deduce the conditions for maximum intensity and zero intensity for a wave of wavelength λ incident normally on a system of N parallel slits, with adjacent slits being separated by a distance d .

[2]

- (ii) For this system of N parallel slits, show that, for small θ , the angular separation $\Delta\theta$ between the centre of a maximum and the adjacent zero is given by:

$$\Delta\theta = \frac{\lambda}{Nd}.$$

[3]

- (d) A student uses a two-slit interference experiment to determine the wavelength of a light source. Another student uses a diffraction grating. The arrangements for measuring angles are the same in the two experiments.

Give **one** reason why the student using the diffraction grating is likely to achieve the more accurate result.

.....

.....

.....

..... [2]

[Total: 13]

- 5 James Clerk Maxwell theorised that the speed of electromagnetic waves in a vacuum is given by the equation:

$$c = \frac{1}{\sqrt{\epsilon_0 \mu_0}} = 3.00 \times 10^8 \text{ m s}^{-1}$$

where ϵ_0 is the permittivity of free space and μ_0 is the permeability of free space.

Physicists initially assumed that this speed must be relative to a hypothetical medium filling all of space. They called this hypothetical medium the 'luminiferous ether' or just 'ether'.

The Michelson-Morley experiment was an attempt to detect the velocity of Earth with respect to the luminiferous ether, the medium in space proposed to carry light waves. First performed in Germany in 1880–81 by the physicist A. A. Michelson, the test was later refined in 1887 by Michelson and Edward W. Morley in the United States.

The procedure depended on a Michelson interferometer, a sensitive optical device that compares the optical path lengths for light moving in two perpendicular directions.

Michelson reasoned that, if the speed of light were constant with respect to the proposed ether through which Earth was moving, that motion could be detected by comparing the speed of light in the direction of Earth's motion and the speed of light at right angles to Earth's motion. No difference was found. This null result seriously discredited the ether theories.

This question considers how the speed of light would be affected **if the ether hypothesis were correct**.

The ether hypothesis in this question makes **two** assumptions:

- 1 The ether is stationary with respect to the Sun.
- 2 Light always travels at speed c relative to the ether.

- (a) A pulse of light is transmitted toward a distant mirror by observer A, who is at rest in the ether.

The light reflects from the mirror and returns to observer A.

Observer B is in a spacecraft moving at speed v parallel to the initial direction of the light pulse, as shown in Figure 5.1.

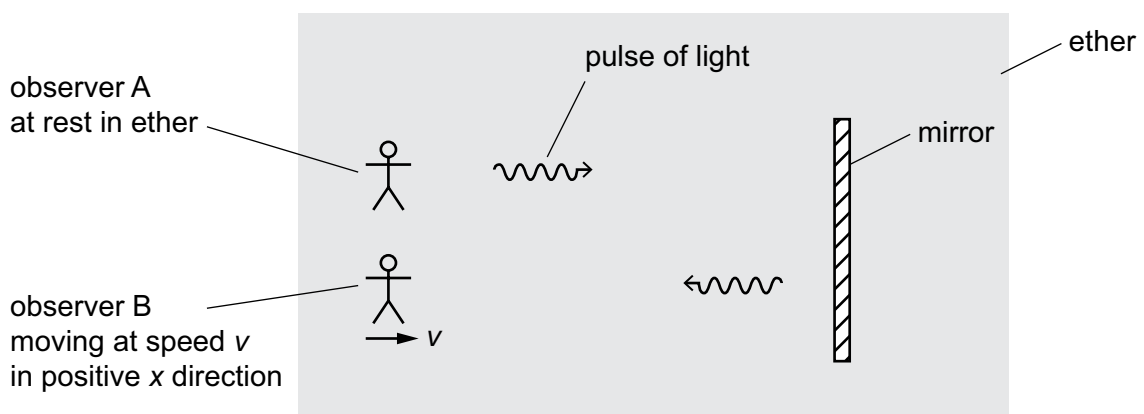

Figure 5.1

Assuming Galilean relativity and the ether hypothesis to be correct, complete Table 5.1 to show the expected speed of the light pulse, in terms of c and v , as it travels to the mirror and back relative to each observer in Figure 5.1.

Table 5.1

	expected speed of light	
	on outward path	on return path
relative to observer A
relative to observer B

[2]

(b) The structure of a Michelson interferometer is shown in Figure 5.2.

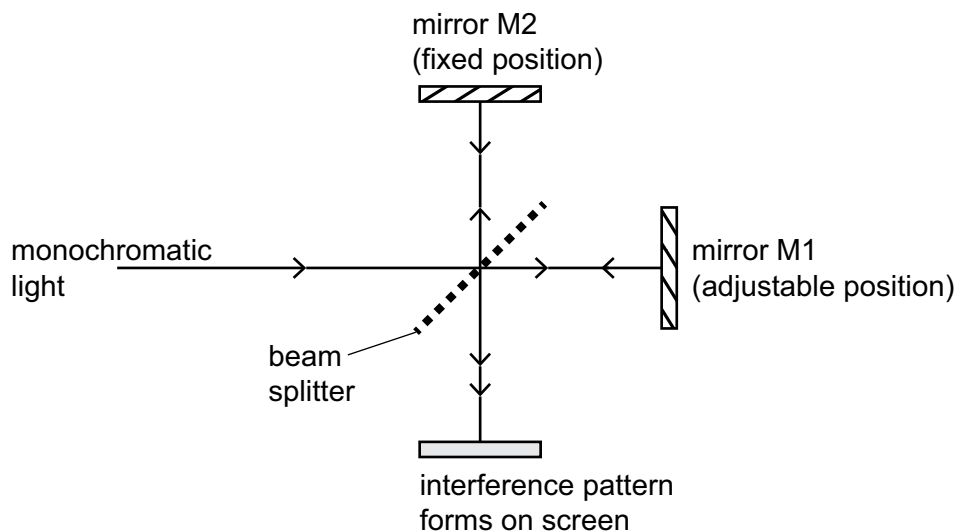

Figure 5.2

A single beam of monochromatic light is split into two coherent beams by the beam splitter. The two beams follow two perpendicular paths of equal length before being recombined when they return to the beam splitter.

This creates an observable interference pattern on the screen that looks similar to the one shown in Figure 5.3.

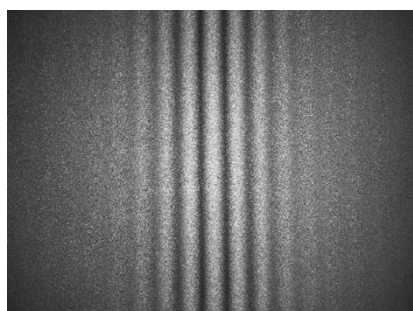

Figure 5.3

(i) Explain what is meant by coherent.

.....
 [1]

(ii) Describe how the interference pattern changes as the length of one path is gradually increased.

.....
 [1]

- (c) Michelson thought that the Earth's motion through the ether would affect the time taken by light to travel along the arms of the interferometer because the path of light relative to the ether would be different on each of the interferometer arms.

Assume that the experiment is carried out at a time when the Earth's speed v relative to the ether is parallel to arm OX of the interferometer as shown in Figure 5.4.

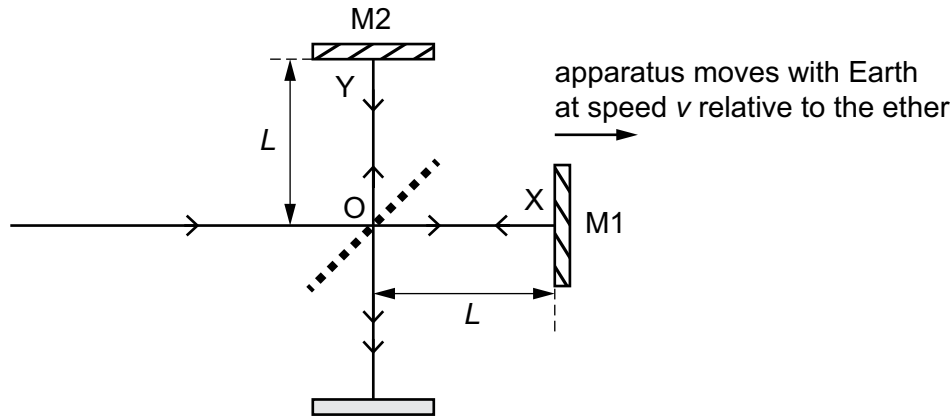

Figure 5.4

The position of M1 is adjusted such that the length of each interferometer arm is L .

- (i) Show that the time t_1 for light to travel from the beam splitter to M1 and back to the beam splitter along path OXO as the interferometer moves through the ether is given by:

$$t_1 = \frac{2cL}{(c^2 - v^2)}.$$

[1]

- (ii) Show that the time t_2 for light to travel from the beam splitter to M2 and back to the beam splitter along path OYO as the interferometer moves through the ether is given by:

$$t_2 = \frac{2L}{\sqrt{(c^2 - v^2)}}.$$

[2]

- (iii) Hence show that the time delay δt , where $\delta t = t_1 - t_2$, caused by the Earth's motion through the ether is given by the equation:

$$\delta t = \frac{2L\gamma}{c} (\gamma - 1)$$

where γ is the Lorentz factor.

[3]

- (iv) The effective length of each interferometer arm was 11.0 m. The speed of the Earth relative to the ether was taken to equal the Earth's orbital speed of about 30 km s^{-1} .

Calculate γ to **10** decimal places (d.p.).

$$\gamma = \dots\dots\dots [1]$$

- (v) Use the equation in **5(c)(iii)** and your answer in **5(c)(iv)** to calculate the expected time delay δt in the Michelson-Morley experiment.

$$\delta t = \dots\dots\dots \text{ s } [2]$$

(vi) The wavelength of light used was 590 nm.

Determine the phase difference $\delta\phi$ in radians between the two beams when they recombine at O.

Assume that the beam splitter does not introduce any phase shifts, and ignore possible frequency shifts.

$\delta\phi = \dots\dots\dots$ radians [2]

(d) The Michelson-Morley experiment was sensitive enough to detect the phase difference described in **5(c)(vi)** but no such change was detected.

By considering how Lorentz length contraction would affect the expression in **5(c)(i)** for t_1 , explain how including such an effect could account for this null result.

.....
..... [3]

(e) Describe how the phase difference calculated in **5(c)(vi)** changes the fringe pattern from how it would appear if, contrary to the first assumption of the ether hypothesis, the ether moved along with the interferometer.

.....
..... [2]

[Total: 20]

Section B

Answer **two** questions from this section.

You are advised to spend about 35 minutes on each question.

- 6 A uniformly charged thin disc of radius R lies in the x - y plane as shown in Figure 6.1.

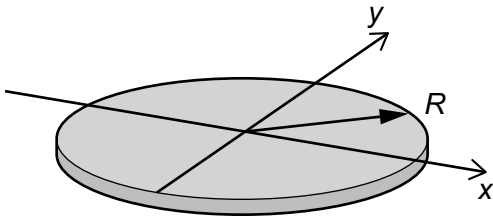

Figure 6.1

The total amount of charge on the disc is Q .

- (a) (i) State an expression for the surface charge density σ in terms of Q and R .

[1]

- (ii) Use your answer in **6(a)(i)** and apply Gauss's law with an appropriately chosen Gaussian surface to show that an approximation for the electric field at the position $(0,0,z)$, where $z \ll R$, is given by:

$$E_z = 2\pi k\sigma$$

where k is a constant you need to determine.

You may wish to draw a diagram to help your answer.

[6]

- (iii) Determine an expression for the electric potential at the point $(0,0,z)$ relative to the origin.

[2]

- (b) The electric field can be determined more accurately than determined in **6(a)** by superimposing the point charge fields of infinitesimal charge elements. This can be done by summing the fields of charged rings of width dr , as shown in Figure 6.2.

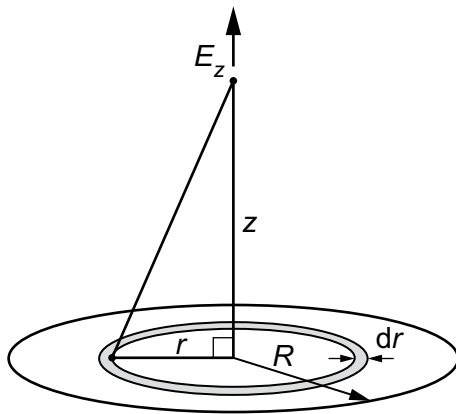

Figure 6.2

- (i) Show that the electric field at position $(0,0,z)$ is given by:

$$E_z = \frac{\sigma}{2\epsilon_0} \left[1 - \frac{z}{\sqrt{z^2 + R^2}} \right]$$

[5]

(ii) Determine an expression for E_z when $z \ll R$.

[2]

(iii) Determine a non-zero expression for E_z when $z \gg R$.

You may wish to use the approximation shown when x is small.

$$(1 + x)^n \approx 1 + nx$$

[2]

(iv) Comment on the form of the expressions in **6(b)(ii)** and **6(b)(iii)**.

.....

.....

.....

..... [2]

[Total: 20]

Turn over

- 7 Figure 7.1 shows a side view and top view of a helicopter hovering stationary in mid-air.

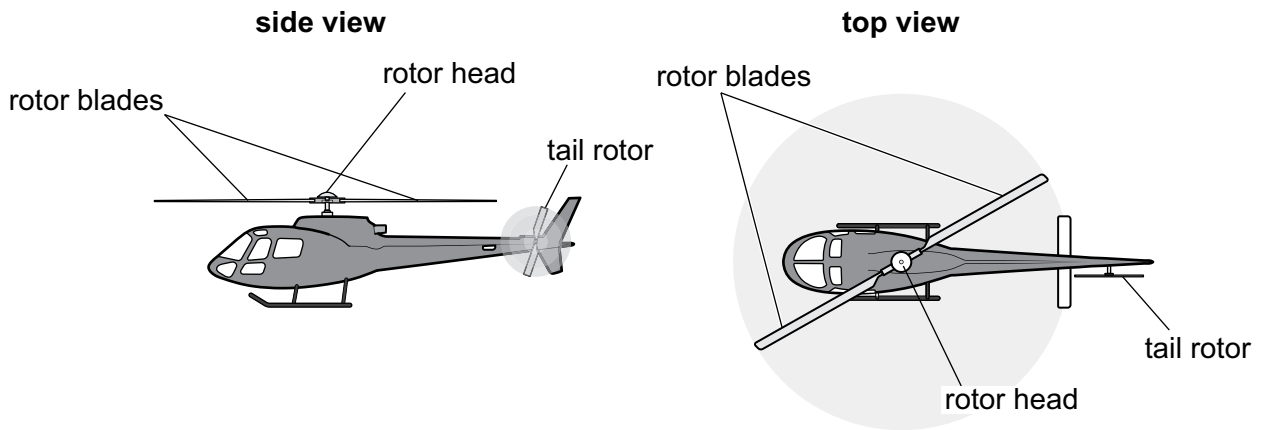

Figure 7.1

The two rotor blades of the helicopter can be modelled as uniform thin rectangular plates of length R and width c , as shown in Figure 7.2.

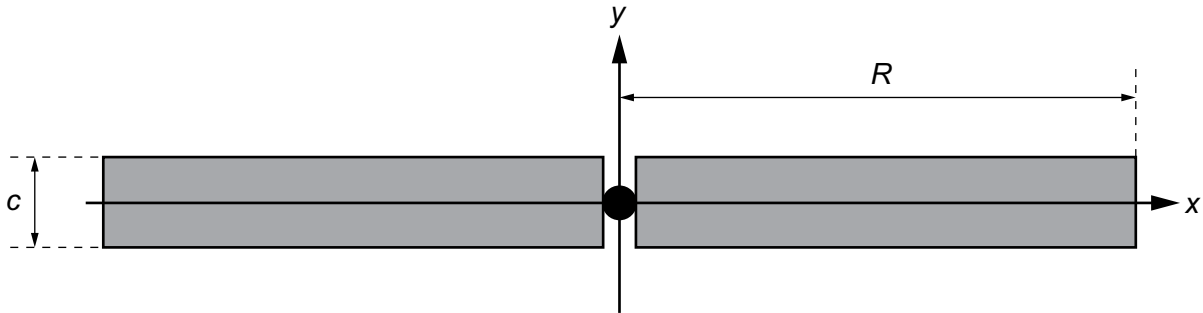

Figure 7.2 (not to scale)

The gap between the two rotor blades is negligible when compared with the total length of the blades.

- (a) (i) Show, from first principles, that the moment of inertia I_x of the rotor blades about the x-axis in Figure 7.2 is given by:

$$I_x = \frac{1}{12}Mc^2$$

where M is the **total** mass of the rotor blades.

[3]

- (ii) Similarly, determine the expression for the moment of inertia about the y-axis, I_y .

$$I_y = \dots\dots\dots [1]$$

- (iii) The perpendicular axis theorem states that the moment of inertia about the z-axis for this case is given by:

$$I_z = I_x + I_y.$$

Show that:

$$I_z = \frac{1}{12}M(4R^2 + c^2).$$

[1]

- (iv) The rotor blades are made of a composite material of density $\rho = 1470 \text{ kg m}^{-3}$. Each blade has length $R = 3.84 \text{ m}$, width $c = 20 \text{ cm}$ and thickness $t = 3.0 \text{ cm}$.

Determine the value of I_z .

$$I_z = \dots\dots\dots \text{ kg m}^2 \text{ [1]}$$

- (v) During take-off, it takes 9.0 s for the angular velocity of the rotor blades to increase from 20 rpm (revolutions per minute) to 320 rpm at a constant angular acceleration.

Calculate the torque required. State the unit.

$$\text{torque} = \dots\dots\dots \text{ unit } \dots\dots\dots \text{ [2]}$$

- (b) The total lift force on the helicopter can be calculated by summing the lift on infinitesimal elements of the blade.

Figure 7.3 shows an element of the rotor blade with width c and length dr at a distance r from the axis of rotation.

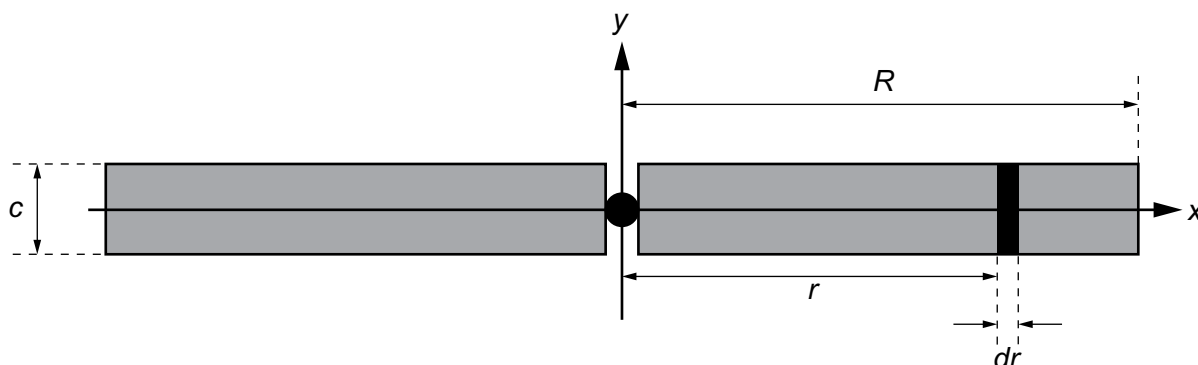

Figure 7.3 (not to scale)

The lift dL on the blade element is given by the equation:

$$dL = \frac{1}{2} C_L \rho (r\omega)^2 c dr$$

where:

C_L is the coefficient of lift

ρ is the density of air and can be taken to be 1.25 kg m^{-3}

ω is the angular velocity of the rotor blades.

- (i) Show that the coefficient of lift C_L is dimensionless.

[1]

- (ii) Show that the total lift force L generated by the two rotor blades is given by:

$$L = \frac{1}{3} C_L \rho \omega^2 c R^3.$$

[3]

- (c) Coning is an effect where the rotor blades of the helicopter tilt upwards from the horizontal, as shown in Figure 7.4.

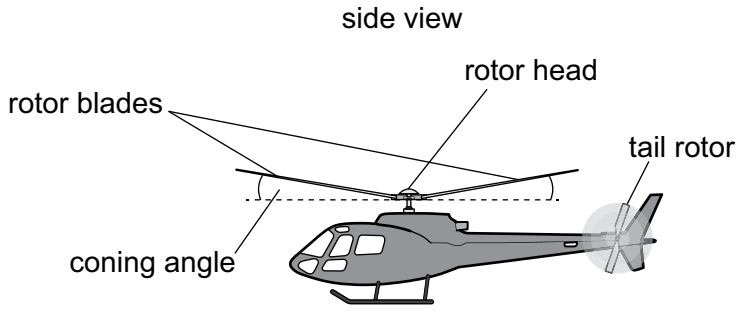

Figure 7.4

- (i) Explain why coning occurs.

.....

 [1]

- (ii) The total mass of the helicopter, including blades, is 2500 kg.

Calculate the angular velocity ω of the rotor blades, in rpm, required for the helicopter to hover at a constant height above the ground with a coning angle of 10.0° .

Use a typical value for C_L of 0.400.

$\omega =$ rpm [3]

- 8 (a) State Faraday's law and Lenz's law.

Faraday's law

.....

Lenz's law

.....

[2]

- (b) A capacitor of capacitance C is fully charged to have a charge Q_0 on one of its plates.

An inductor of inductance L and a switch S are connected to the charged capacitor to form a series circuit, as shown in Figure 8.1.

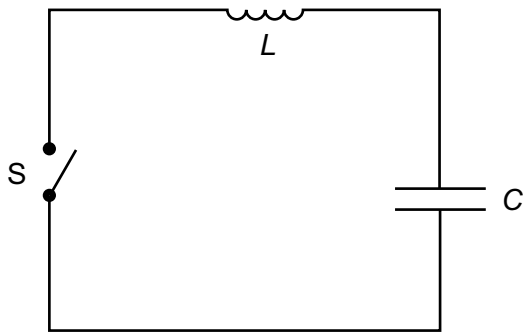

Figure 8.1

At time $t = 0$, the switch is closed.

- (i) By differentiating the total energy in the circuit with respect to time, show that charge Q on one of the capacitor plates obeys the second order differential equation:

$$L \frac{d^2 Q}{dt^2} + \frac{Q}{C} = 0.$$

[3]

(ii) Hence determine an expression for Q as a function of time.

[2]

(c) Initially, the capacitor in Figure 8.1 is fully charged with a charge of 1.5 mC. The inductor has an inductance of 4.0 mH, and the capacitor has a capacitance of 50 μ F.

At time $t = 0$, the switch is closed.

(i) Calculate the time at which the capacitor is next fully charged.

$t = \dots\dots\dots$ s [2]

(ii) On Figure 8.2, sketch a graph for time $t = 0$ to $t = 6.0$ ms to show the variation of the charge Q on one of the capacitor plates.

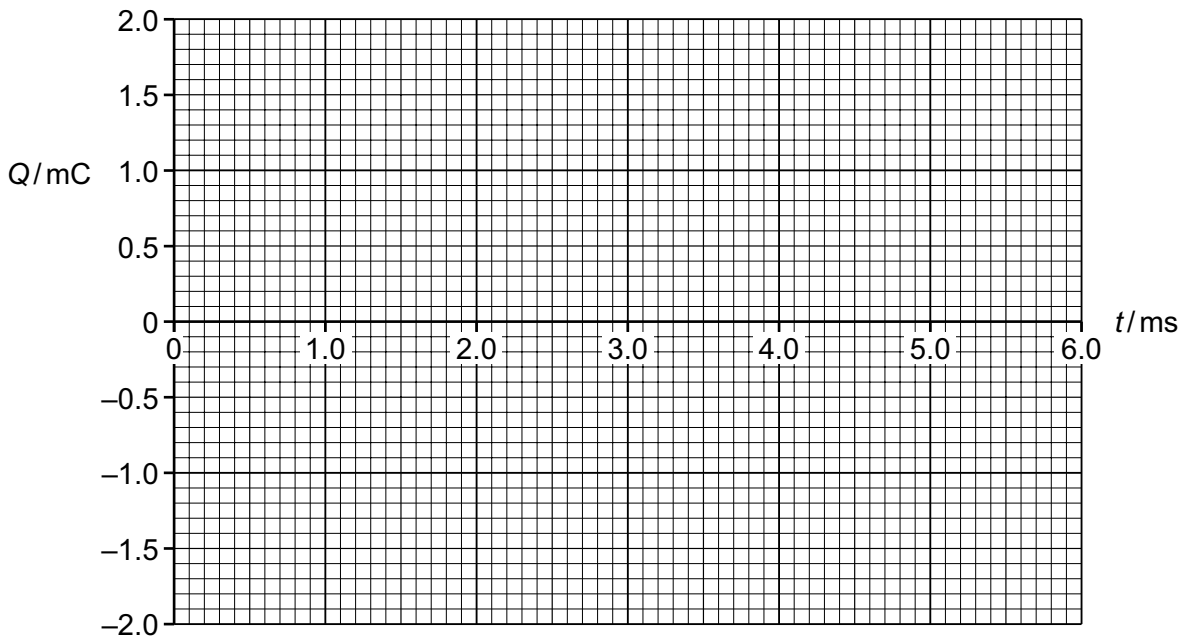

Figure 8.2

[2]

- (iii) Calculate the first time at which the energy stored in the capacitor is equal to the energy stored in the inductor.

$t = \dots\dots\dots$ s [2]

- (iv) On Figure 8.3, sketch a graph to show the variation with time of the energy E stored in:

- the capacitor and label this graph E_C
- the inductor and label this graph E_L .

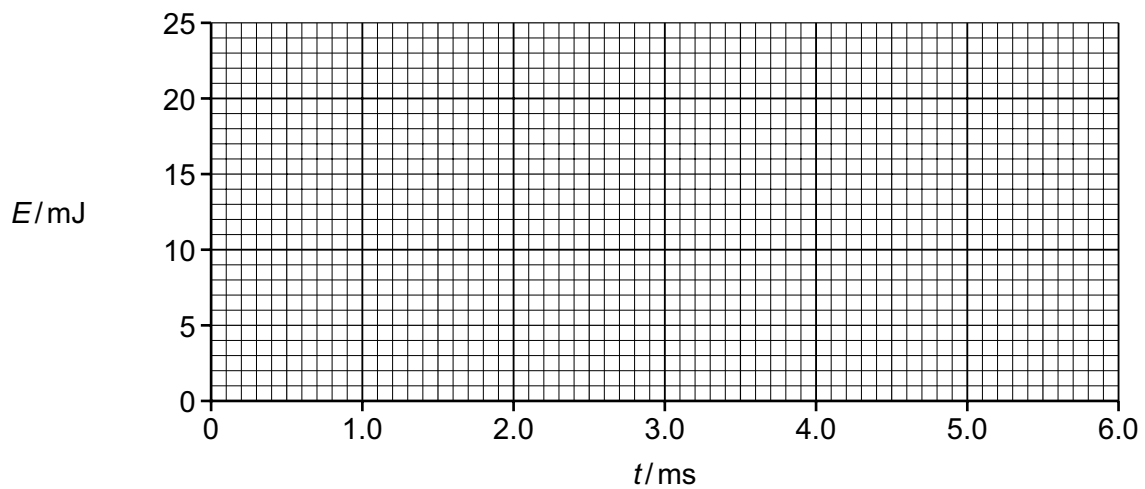

Figure 8.3

[3]

(v) A resistor is added in series with the inductor and the capacitor.

(A) Sketch on Figure 8.4 how the current I in the resistor varies with time.

Show at least four cycles of the capacitor discharging and charging. You do **not** need to add values to your graph.



Figure 8.4

[2]

(B) Without calculation, state how the period in Figure 8.4 compares with the period in Figure 8.2. Give a reason for your answer.

.....
.....
..... [2]

[Total: 20]

BLANK PAGE

Permission to reproduce items where third-party owned material protected by copyright is included has been sought and cleared where possible. Every reasonable effort has been made by the publisher (Cambridge University Press & Assessment) to trace copyright holders, but if any items requiring clearance have unwittingly been included, the publisher will be pleased to make amends at the earliest possible opportunity.

Cambridge International Education is the name of our awarding body and a part of Cambridge University Press & Assessment, which is a department of the University of Cambridge.