

# Building Information Modelling (BIM): The Way Forward – Common BIM Standards for Lift Design Submission

Presented by

Jake Ang

Senior Engineer

Electrical and Mechanical Engineering Group

9 January 2023



# Topics

## 1) Using BIM to transform Regulatory Approval Process - CORENET X

a) Brief on CORENET X

## 2) What does this mean for Lift and Escalator (L&E) Sector?

a) CORENET X Timeline

b) Benefits of BIM for Design Plan Submission and Processing

c) Submission Standards in BIM for Design Plan Approval

## 3) BIM Development for L&E

a) BIM Guides

b) Generic BIM Family Lift Models

## 4) Implementing BIM in your firm

a) Sharing by Kone



# Announcement of CORENET X by Min. Desmond Lee at IBEW 2021

Opening Address by Minister Desmond Lee at the Opening Ceremony of the International Built Environment Week 2021



One-stop integrated digital shopfront for the industry

Streamline more than 20 existing approval touchpoints across agencies

Clear, consolidated and coordinated response to QPs

Tap on new digital technologies to enhance regulatory submission process



# Vision of CORENET X

A Future Ecosystem of Regulatory Approval of Building Works that Accelerates The Transformation of the Construction Industry

## FIRST IN THE WORLD One-Stop Integrated Digital Shopfront

### TRANSFORMATION of INDUSTRY

- Promote design coordination and teamwork
- Promote digitalization of construction sector
- Support IDD<sup>1</sup> & DfMA<sup>2</sup> imperatives

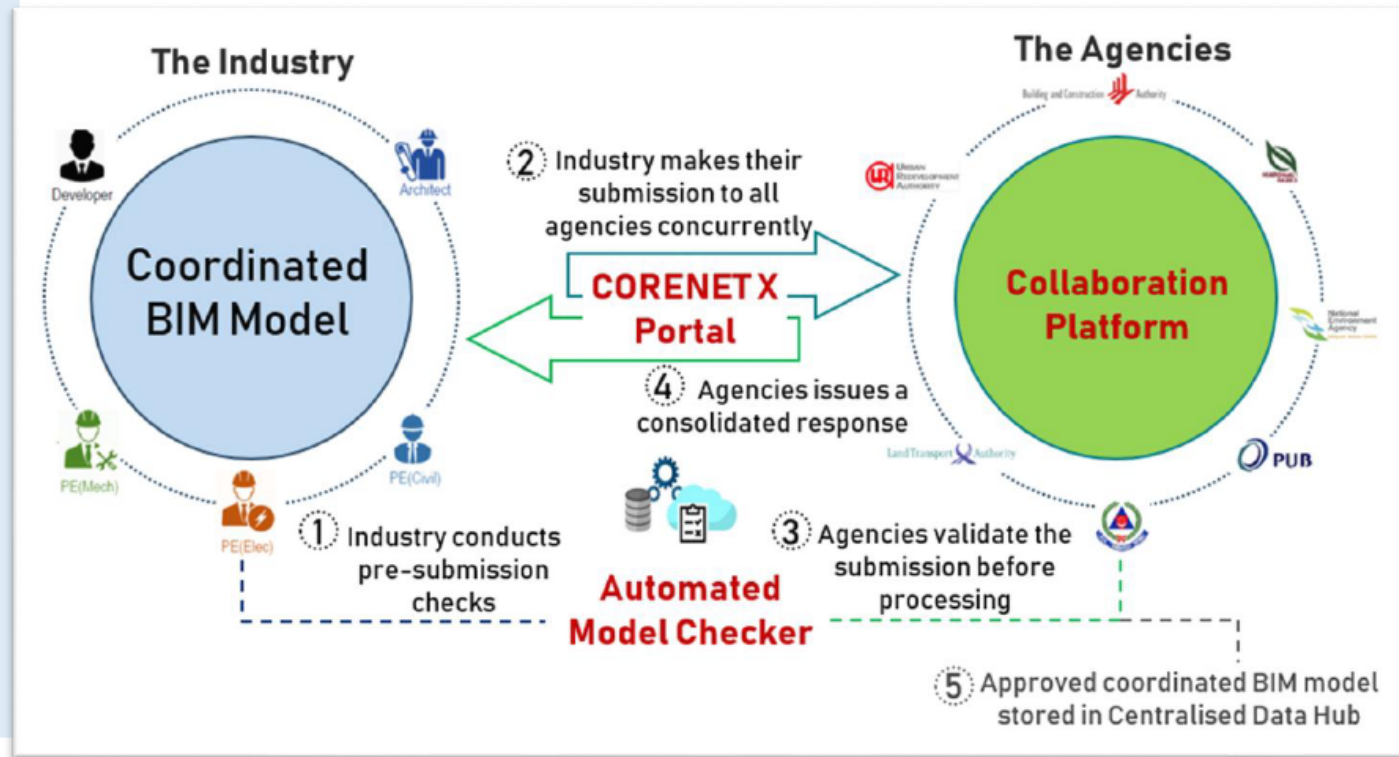

### TRANSFORMATION of REGULATORY AGENCIES

- Reduce silos, iterations & condense touchpoints
- Embrace collaboration & raise productivity amidst rising demands
- Improve accessibility & centralise information towards a Single Source of Truth

<sup>1</sup> IDD is the use of digital technologies to integrate work processes and connect stakeholders working on the same project throughout the construction and building life-cycle

<sup>2</sup> DfMA is a continuum of various technologies and methodologies that promote offsite fabrication from prefabricated components to fully integrated assemblies across the structural, architectural and Mechanical/ Electrical disciplines.

# Key Work Areas of CORENET X

## 2. TECH ENABLERS ●

### [Collaboration Platform]

Facilitate agencies' collaboration and coordination in regulatory processing

### [Automated Model Checker]

Enhance productivity for both the industry and agencies by automating part of the code compliance checks

### [OpenBIM Format]

Support interoperability and localized requirements – critical for both CP and MC



## 1. NEW REGULATORY PROCESS THROUGH SERVICE JOURNEY

- **Discovery Phase:** Service Blueprint and quick wins
- **Envisioning Phase:** Redesign of regulatory processes

## 3. GETTING READY FOR CORENET X ●

- **INDUSTRY:** Onboarding, Collaboration and Training on new process and requirements

# Automated Model Checker



- **Auto-Checking** for regulatory non-compliance against rules across 7 key agencies, across 3 building disciplines (Architectural, Civil & Structural, Mechanical & Electrical)
- **Allow pre-check** by industry prior to submission

Sample views extracted from prototype

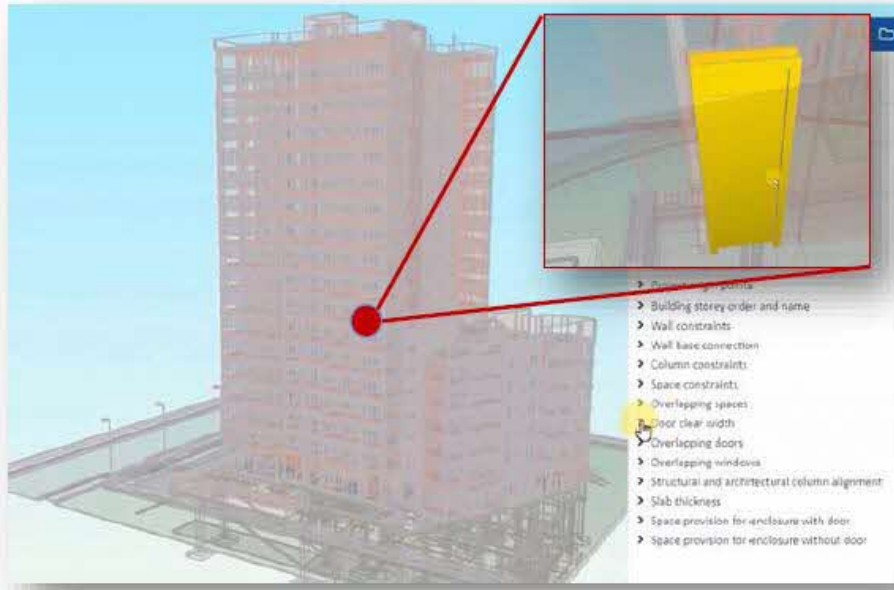

Highlight non-compliance - Door did not meet minimum door width requirement



Summary report on number of non-compliances detected

## SELF-CHECK

Allow industry to self-check prior to submission



## EFFICIENT

Improve turnaround time and overall efficiency



## CONSISTENT

Ensure consistent interpretation of requirements



# OpenBIM Format



## CURRENT REALITY

- Industry uses diverse Proprietary BIM software available in the market



## IFC (Industry Foundation Class)

An international open BIM format to facilitate interoperability in building and construction industry

## CURRENT GAP

- A need for **platform-neutral** format to facilitate **collaborative workflows**
- A need for **interoperability** among different software

## DEVELOPMENT OF IFC-SG

- **Adoption of IFC**
- Development of **extension IFC-SG** common representation for **local** requirements and regulatory needs

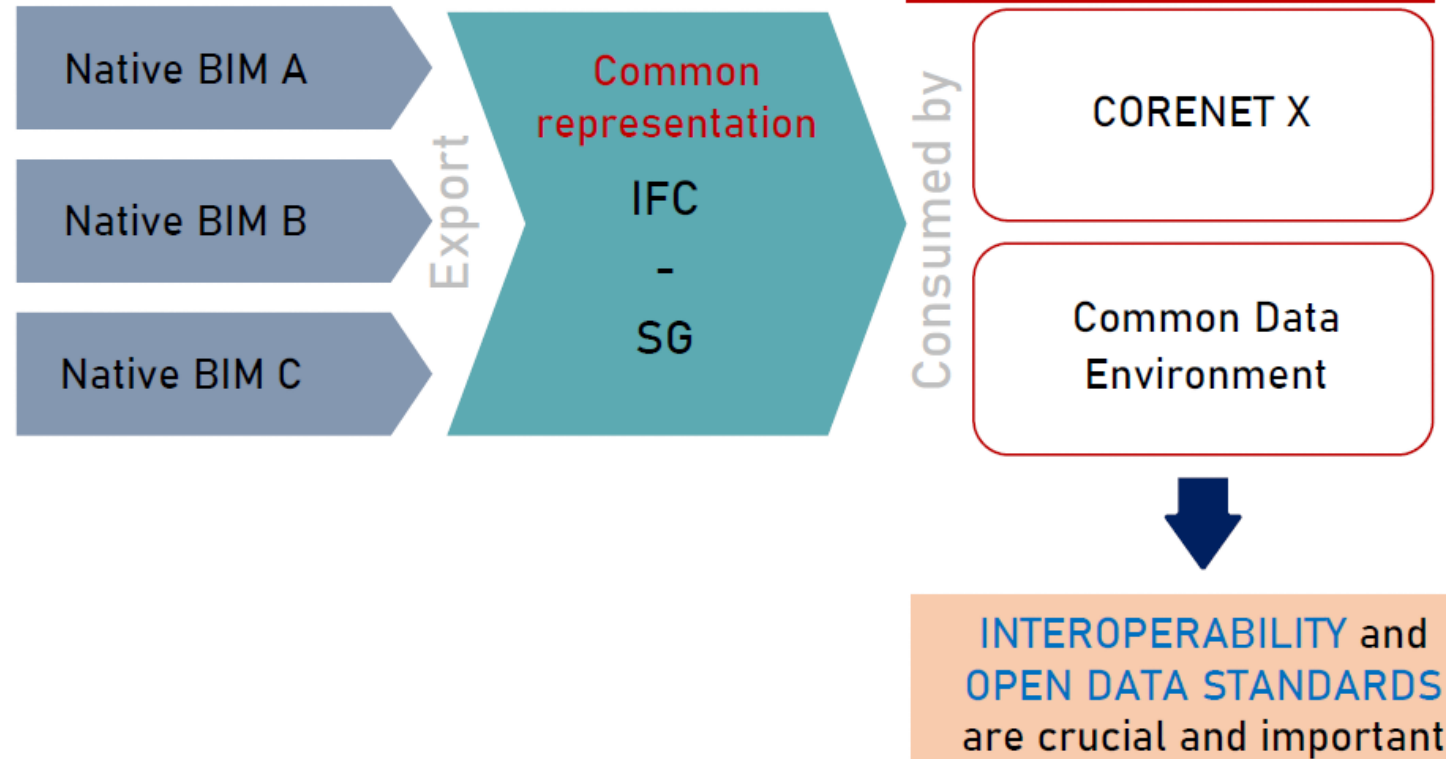

# Why this will benefit the Built Environment Sector?

## PRODUCTIVITY AND DIGITALIZATION

- Promote design **coordination** and teamwork with other project parties
  - E.g. allocation of lift well space and motor room access path
- **Reduce rectification** works during Construction Stage
  - Early design approval reduces abortive works in rectifying non-compliance found during testing and commissioning
- Streamline **Asset Management** for downstream facility management
  - Building owners receiving the BIM models will be able to schedule and plan for maintenance of equipment and management of facility
- **Efficiency** in Regulatory Submissions and Approvals
  - Automated Checkers

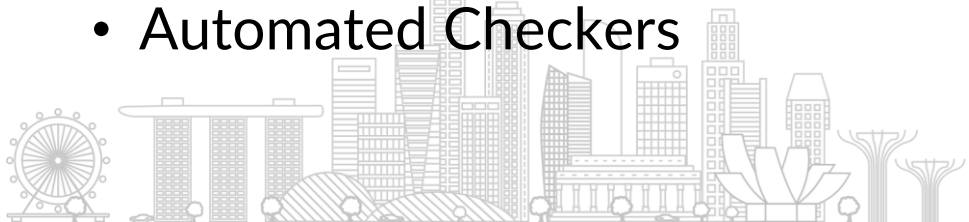

# What does this mean for the L&E Industry?

## REGULATORY REQUIREMENTS

- CORENET X is slated for implementation by end-2023
  - Plan submissions (>5,000sqm in BIM would be mandatory)
- All disciplines (Architecture, Structural and MEP) will be required to submit to the regulatory authorities in BIM under CORENET X
  - This would include plan submissions for **Fixed Installations (FI) – (Lifts, Escalators and Mechanised Car Parking Systems)** which would be required in the upcoming regulations for FI in 2023



# BIM Development for L&E

To prepare the L&E industry for submission in BIM:

- **Guide** on BIM e-submission for Fixed Installation (FI)
  - Provide details on the **required components and their properties** that are to be shown in BIM models
- **Firms with existing BIM models** are invited to check with BCA on their compliance with the BIM guide as well as **participate in trials** on the use of BIM for submissions.
- **For Firms which are not BIM-ready yet, generic lift component family models will be provided** by BCA for reference and for use in preparing BIM models for plan submissions.

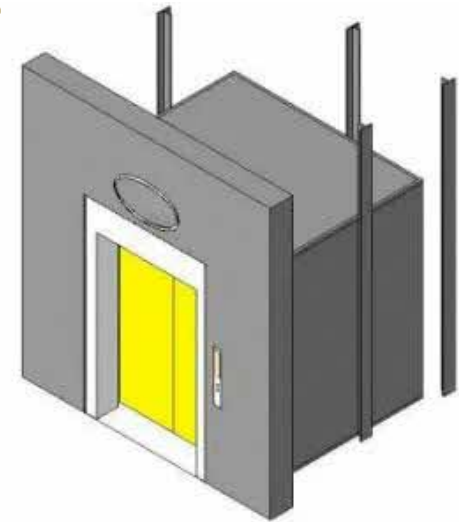

# BIM Development for L&E – BIM Guide

## Current State

Firms have varying standards and level of details

- BIM guide will provide guidance in a common baseline standards for firms to follow:
  - Terminology
  - Required components to be included
  - Required parameters to be included
  - Equivalent to LOD 350\*

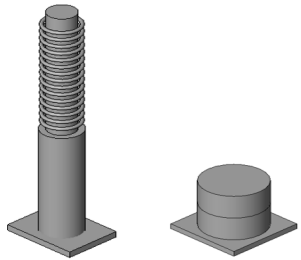
Car/Counterweight Buffer		
		
	<b>Parameter Name</b>	<b>Sample Value</b>
<b>Intrinsic Parameters</b>	Rated Speed	2m/s
	*not MC parameter	
	Total Stroke	100mm
	Impact Mass Range	450kg – 3000kg
<b>Baseplate</b>	*not MC parameter	
	Width	200mm
	Length	200mm
	Height	20mm
<b>Column</b>	Diameter	150mm
	Height	200mm
<b>Stroke*rubber</b>	Diameter	100mm
	Height	175mm
<b>Others</b>	Is buffer fixed to lift car?	Yes/No

\*not MC parameter but modelling parameter only

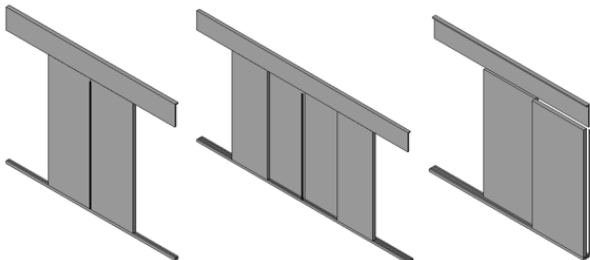
Landing Door and Landing Door Lock		
		
	<b>Parameter Name</b>	<b>Sample Value</b>
<b>Body</b>	Width	50mm
	Length	900mm
	Height	2100mm
<b>Others</b>	Vertically sliding for goods lift?	Yes/No
	Number of panel	2/4/6
	Opening direction	Side/Centre
	Door lock openable from pit?	Yes/No

Safety Gears		
		
	<b>Parameter Name</b>	<b>Sample Value</b>
<b>Intrinsic Parameter</b>	Rated Speed	1.0m/s
	Width	150mm
<b>Safety Gear Housing</b>	Length	150mm
	Height	200mm
<b>Guide Rail Slot</b>	Width	25mm
	Depth	140mm
<b>Type</b>	Type	Instantaneous / Progressive

\*not MC parameter but modelling parameter only

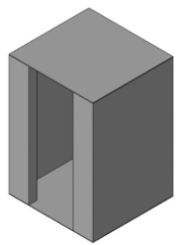
Lift Car	
	
<b>Parameter Name</b>	<b>Sample Value</b>
Clear Height	2400mm
Clear Width	1500mm
Clear Depth	1400mm
Weight Load Capacity	980kg
Passenger Capacity	13 pax
Travel Height	25000mm
Control Device Operable Distance	500mm
Rope Count	3
Rated Speed	1.0m/s
External Height of lift car*	2900mm
Width *	1800mm
Depth*	1600mm

\*not MC parameter but modelling parameter only

# BIM Development for L&E – BIM Guide

## Required parameters

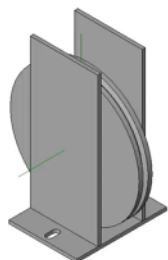
Governor		
		
Intrinsic Parameter	Parameter Name	Sample Value
Baseplate	Rated Speed	1.5m/s
	Width	250mm
	Length	320mm
Pulley	Height	400mm
	Diameter	320mm
	Groove Angle	15
Type	Groove Depth	8mm
	Type	Bi-Directional / Machine Room Less

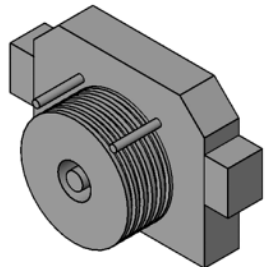
Traction Machine and Brakes		
		
*gearless		
Intrinsic Parameter	Parameter Name	Sample Value
Body	Rated Speed	1.5m/s
	Number of ropes	6
	Rope Diameter	10mm
	Outer Diameter	600mm
	Inner Diameter	400mm
	Width	250mm

**Extrinsic**  
(geometric)

**Width**

**Length**

**Height**

**Diameter**

**Intrinsic**  
(design details)

**Rated Speed**

**Pax capacity**

**Weight Load**

**Opening Directions**

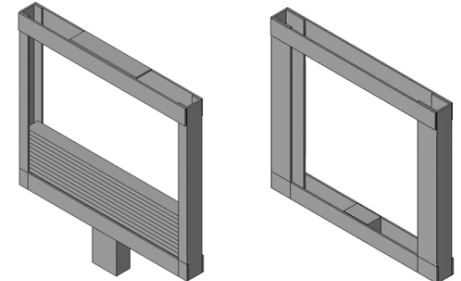
Counterweight		
		
Intrinsic Parameter	Parameter Name	Sample Value
Frame	Weight	1500kg
	Width	200mm
	Length	1200mm
Weight Plate	Height	2000mm
	Width	180mm
	Length	1180mm
Guide (Shoes)	Height	150mm
	Width	111mm
	Length	47mm
Sheave	Height	78mm
	Diameter	400mm

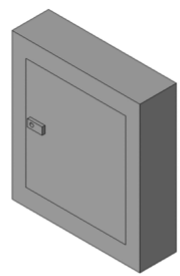
Control Panel and Cabinets		
		
Body	Parameter Name	Sample Value
Body	Width	250mm
	Length	750mm
	Height	950mm
Others	Type	Control Panel, EBOPS/UPS, E&I Panel

# BIM Development for L&E – BIM Guide

## Checklist

## Verify Compliance to Code

- Checklist in BIM Guide on key requirements to look out for at design stage
- For e.g. requirements in Lift Well:
  - Clearance between lift car and lift shaft wall (min. 20mm, max. 150mm on side of lift car door)
  - Clearance between counterweight and lift shaft wall (min. 20mm)
  - Clearance between lift car and counterweight (min. 50mm)
  - Position of pit access ladder (min. 1,500mm above landing sill)

	others	
	<ul style="list-style-type: none"> <li>a) Distance between consecutive landing doorsills lift landings</li> <li>b) Length of guiderail</li> <li>c) Position and size of vent opening</li> </ul>	<p>pulleys (if applicable)</p> <ul style="list-style-type: none"> <li>• For distance &gt;11m: Emergency doors of minimum 850mm width x 2000mm height must be provided)</li> <li>• For consecutive landing sills with distance &gt; 18m, rescue hooks will be required in accordance with SSS50:2020 Section 5.2.3.5 [Will be under SCDF requirement]</li> <li>• Minimally allows for additional 100mm travel from car/counterweight's highest position</li> <li>• Topmost part of lift shaft</li> <li>• Total unobstructed area of at least 1% of horizontal section of the lift shaft</li> <li>• Minimum 0.1 m<sup>2</sup> for each lift in the lift shaft</li> </ul>
		<b>Lift Shaft</b>
Clearance Distances (involving lift shaft walls, lift car, counterweight, and pit access ladder)	a) Clearance between lift car and lift shaft walls	<ul style="list-style-type: none"> <li>• Minimum 20mm (except on the side used for loading/unloading for lift car)</li> <li>• Maximum 150mm for the side of lift car doors</li> </ul>
	b) Clearance between counterweight and lift shaft walls	Minimum 20mm
	c) Clearance between lift car and counterweight	Minimum 50mm
	d) Position of pit access ladder with respect to lift shaft wall and lift landing entrance	<ul style="list-style-type: none"> <li>• Minimum 200mm clearance between back of rung of ladder and lift shaft wall</li> <li>• Maximum distance of 600mm between middle of ladder rungs and edge of lift landing entrance</li> <li>• Minimum 1500mm vertical distance between top of ladder uprights (or other suitable handhold) and landing sills</li> </ul>
		<b>Machine Room (if applicable)</b>
Structural	a) Headroom from machine room floor	<ul style="list-style-type: none"> <li>• Minimum 2100mm at working areas (or minimum 1500mm for secondary machine room)</li> <li>• Minimum 1800mm at other areas</li> </ul>
	b) Difference in levels of machine room / machinery space floors	<ul style="list-style-type: none"> <li>• For level difference of &gt; 380mm: A standard railing of minimum 1100mm height shall be provided at the edge of the higher level, and stairs/ladders shall be provided for access between levels</li> </ul>
	c) Access ways	Minimum 500mm width (or 400mm where there are no moving parts or hot surfaces)
	d) Dimensions of machine room and maintenance doors	Minimum 1000mm width x 2000mm height
	e) Height of curb around openings for ropes	Minimum 50mm
	a) Angle of inclination to the	Maximum 60°



# BIM Development for L&E – BIM Guide

## Lift Components

- Lift Components mentioned in SS 550 are split into two groups:
  - [1]Requirement Components which are **key lift components** to be included in the BIM model as they contain **key parameters**
  - [2]Peripherals components which are **secondary components** that do not contain key parameters but are usually included in BIM models to **complete the whole lift design**

Generic family model provided

Identified Objects	Object Type
Lift Landing Door	Component
Lift Car	Component
Traction Machine	Component
Governor	Component
Control Panel	Component
Counter Weight	Component
Sheave	Component
Buffer	Component
Ventilation Opening	Part of Component
Lift Car Apron	Part of Component
Lift Car Door	Part of Component

Identified Objects	Object Type
Access Door	Peripheral
Ladder	Peripheral
Wire-mesh Screen	Peripheral
Door	Peripheral
Ship's Ladder	Peripheral
Handrail	Peripheral
Maintenance Door	Peripheral
Guardrail	Peripheral
Lift Landing Door Frame	Peripheral
Trap Door	Peripheral
Counter Weight Screen	Peripheral



# Example – Lift Landing Door

- Parameters include dimensions such as outer dimension and width and intrinsic parameters such as number of panels, opening direction, vertically sliding for goods lift or whether door lock is operable from pit
  - E.g. “Checks on whether the door lock is operable from pit” for those that has no access door to the pit. Door lock within 1.8m high and within 0.8m horizontally from pit ladder



Landing Door and Landing Door Lock		
	<b>Parameter Name</b>	<b>Sample Value</b>
<b>Body</b>	Width	50mm
	Length	900mm
	Height	2100mm
<b>Others</b>	Vertically sliding for goods lift?	Yes/No
	Number of panel	2/4/6
	Opening direction	Side/Centre
	Door lock operable from pit?	Yes/No



# Example - Buffer

- Parameters include dimensions such as height and intrinsic parameters such as buffer stroke or if it is fixed to the lift car
  - Buffer stroke is required for calculation of the gravity stopping distance
  - “fixed to lift car” for models where buffer is installed to hit on pedestal on pit floor

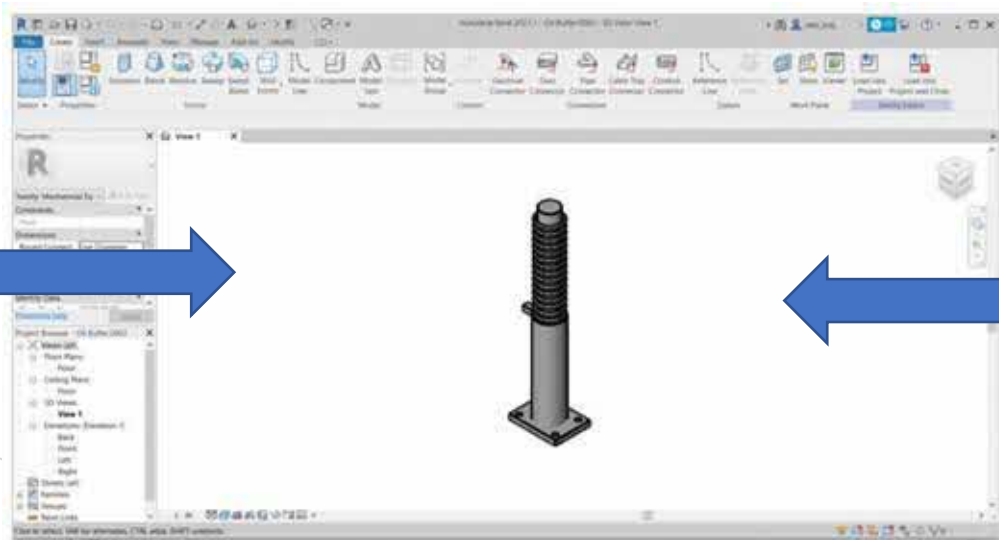

**Car/Counterweight Buffer**

	Parameter Name	Sample Value
Intrinsic Parameters	Rated Speed	2m/s
	*not MC parameter	
	Total Stroke	100mm
	Impact Mass Range	450kg – 3000kg
Baseplate	Width	200mm
	Length	200mm
	Height	20mm
Column	Diameter	150mm
	Height	200mm
	Diameter	100mm
Stroke*rubber	Diameter	100mm
	Height	175mm
Others	Is buffer fixed to lift car?	Yes/No

\*not MC parameter but modelling parameter only



# BIM Development for L&E – Generic BIM Family Lift Models

Firms can download for their own use

- BCA will provide generic lift component templates in Revit for firms to use
  - Able to modify components according to each brand/model's specifications

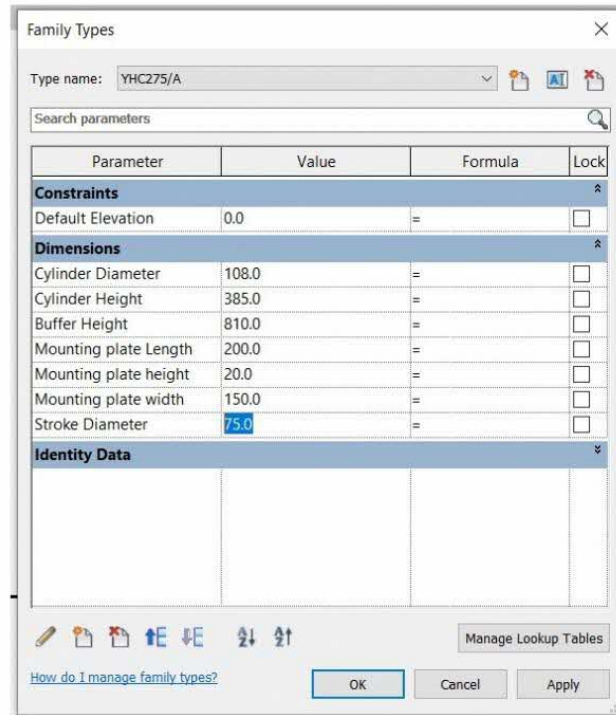
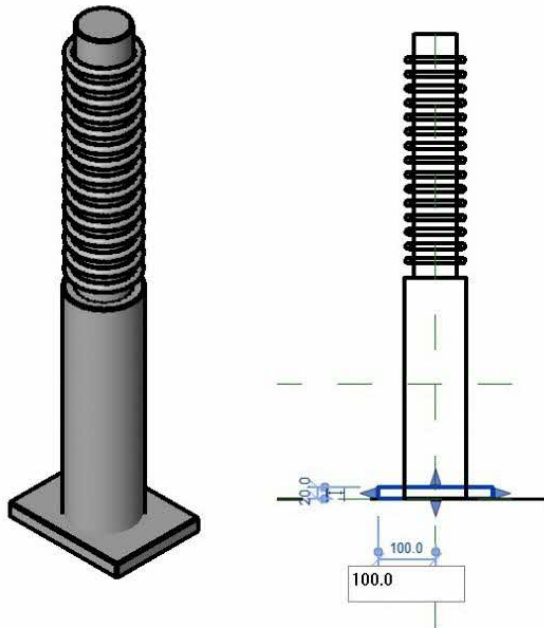

Identified Objects	Object Type
Lift Landing Door	Component
Lift Car	Component
Traction Machine	Component
Governor	Component
Control Panel	Component
Counter Weight	Component
Sheave	Component
Buffer	Component



# Timeline



**\*BIM submissions required for plans (>5,000 sqm)**

**Details on BIM Guide and generic Lift component Templates will be provided on BCA's website by 1Q2023**



# Implementing BIM in your firm

## Kick-start building BIM capability

- **Understand and believe** that BIM will bring benefits to your operation
- **Define** requirements, schedule, scope and process of using BIM before starting on your projects
- **Assign** roles and responsibilities to your team members including skill proficiency and training
- **Put in place** procedures to follow for all interactions across all stages of projects from conceptualizing, schematic design, detailed design, documentation, installation, coordination with project parties and asset management
- Attend BIM course
  - Certification in BIM Modelling -MEP track (BCA Academy)  
[www.bcaa.edu.sg/what-we-offer/academic-programmes?CourseId=0c7405c1-e404-42af-8f40-c3824accc660](http://www.bcaa.edu.sg/what-we-offer/academic-programmes?CourseId=0c7405c1-e404-42af-8f40-c3824accc660)
  - Certification on BIM Management (BCA Academy)  
[www.bcaa.edu.sg/what-we-offer/academic-programmes?CourseId=2a0f8947-88ee-423b-99c6-5a336c01a41a](http://www.bcaa.edu.sg/what-we-offer/academic-programmes?CourseId=2a0f8947-88ee-423b-99c6-5a336c01a41a)
  - BIM course catered specifically for Lift and Escalator (Autodesk)



# Thank you



@BCASingapore

