

Circular No : URA/PB/2020/05-SPG
Our Ref : DC/ADMIN/CIRCULAR/PB_20
Date : 13 Jul 2020

CIRCULAR TO PROFESSIONAL INSTITUTES

Who should know

Developers, building owners, property managers, architects and engineers.

LOADING BAY DESIGN AND OPERATION GUIDE FOR COMMERCIAL BUILDINGS

1. The [Loading Bay Design and Operation Guide](#) facilitates the better design and management of loading bay operations by commercial building owners. This guide provides information, best practices and recommendations regarding the operation of the Loading Bay within commercial buildings
2. The best practices shared should achieve the following objectives for the Loading Bay:
 - Efficient loading/ unloading turnaround time
 - Improve traffic safety and goods flow
 - Adapt to changing delivery trends
3. We urge all building owners, developers and QPs to refer to the Best Practice Guide when developing new commercial buildings or when redeveloping existing commercial buildings, especially for buildings with large retail components. In cases where it is difficult to adhere to the good practice for the design and operation of the Loading Bay, we encourage buildings owners to explore other means to achieve the same design and operation principles.
4. The Best Practice Guide supplements the technical agencies' prevailing Code of Practices, requirements or design standards, which should take precedence.
5. I would appreciate it if you could convey the contents of this circular to the relevant members of your organisation. We have updated the same in the [Development Control Handbooks](#). You are advised to refer to these Handbooks for the most updated guidelines. Answers to anticipated questions can be found in [Appendix 1](#).
6. For other information on the Master Plan, urban design guidelines, private property use and approval, car park locations and availability, private residential property transactions, and conservation areas and buildings, use URA SPACE (Service Portal and Community e-Services). This is an online portal with useful data and visualisation to help building professionals, business operators and the general public in their decision-making. It consolidates detailed information on

land use and private property into a one-stop platform presented on geospatial maps. For feedback or enquiries, please [email](#) us.

Thank you.

CHIU WEN TUNG
GROUP DIRECTOR (RESEARCH AND DEVELOPMENT)
for CHIEF EXECUTIVE OFFICER
URBAN REDEVELOPMENT AUTHORITY

*Join URA's mailing list to get the latest updates on current and future plans and developments around Singapore.
Click [here](#) to subscribe.*

Published by:
Urban Redevelopment Authority
45 Maxwell Road, The URA Centre, 069118
www.ura.gov.sg

This guide is co-developed with industry practitioners to document industry best practices to help commercial building owners and professionals design and manage Loading Bay operations. The contents of this best practice guide will continue to be revised to consider latest practices. URA shall not be responsible for any loss, damage, or injury that may be suffered by any person in connection with the recommendations in this guide.

All rights reserved. No part of this publication may be reproduced, stored in a retrieval system, or transmitted in any form or by any means, electronic, mechanical, photocopying, recording or otherwise, without the prior written permission of the Urban Redevelopment Authority.

Copyright © 2020 Urban Redevelopment Authority

Foreword

At the Urban Redevelopment Authority (URA), we are constantly looking for ways to improve the built environment of Singapore as a great city to live, work and play. Developed in partnership with building professionals and logistics operators, this Loading Bay design and operation best practice guide illustrates how commercial buildings can be designed for safe and efficient deliveries.

Deliveries and collections are essential to businesses and an important aspect of the city's functions. Having well-designed and operated loading bay will bring about benefits to the building owners and tenants such as minimising conflicts between building users and delivery personnel, having a safe and efficient working environment for loading bay users and reducing long term operation costs.

We are pleased to compile this simple and practical guide, with accompanying graphical representations, to provide easy reference and illustration of the practices. Professionals and commercial building owners can also refer to the end of this guide for a summary of the suggested best practices.

Developing the guide involved close engagement of URA with the industry partners and professionals. We would like to thank the practitioners and professional bodies i.e. Real Estate Developers' Association of Singapore, Singapore Institute of Architects, and Singapore Logistics Association which have contributed their knowledge and expertise towards making this guide.

We hope that commercial building owners and professionals in the industry will find this guide useful and will continue the partnership to come up with innovative ways to make Singapore a great city.

Chiu Wen Tung
Group Director (Research and Development)
Urban Redevelopment Authority

Contents

- 01 Introduction** 5
- 02 Efficient Loading Bay** 7
 - 2.1 Weather Protection 7
 - 2.2 Ease of Access to Retail Outlets 8
 - 2.3 Use of Goods Lifts 10
 - 2.4 Storage Areas 10
 - 2.5 Use of the Loading Bay 11
 - 2.6 Providing Clear Information 12
 - 2.7 Leveraging on IT Systems 13
- 03 Improving Traffic Safety and Goods Flow** 14
 - 3.1 Delivery Ingress and Egress 14
 - 3.2 Designing the Loading Bay Access Point 15
 - 3.3 Design of Loading Bay Platform 16
 - 3.4 Managing the Refuse and Collection System 17
 - 3.5 Positioning of Loading Bay Barriers 19
 - 3.6 Protection of Building Interior Along Delivery Corridors 20
 - 3.7 Protection of Structural Building Columns at the Loading Bay 21
 - 3.8 Lighting 22
- 04 Adapting to Changing Delivery Trends** 23
 - 4.1 Vehicular Goods Lifts 23
 - 4.2 Noise Exposure Mitigation 23
 - 4.3 Managing Short-Term Food Deliveries 25
- 05 House Rules** 27
- 06 Checklist** 28

The list of good practices is categorised to achieve the 3 focus areas of the loading bay:

- 
a) Enabling efficient loading/ unloading turnaround time
- 
b) Improving traffic safety and goods flow
- 
c) Adapting to changing delivery trends

Commercial building owners and professionals should read this best practice guide in conjunction with other agencies' guidelines, such as the Land Transport Authority's Code of Practice on Vehicle Parking Provision in Development Proposals.

01 Introduction

The design and operation of a loading bay are essential to the business operations of a building. Both delivery and service vehicles can undertake safe and efficient operations if commercial building owners and professionals provide a loading bay that meets users' needs and operate it in a safe manner.

This guide serves to provide information, recommendations and good practices in the operation of the Loading Bay within commercial buildings.¹ In cases where commercial building owners and professionals are unable to adapt to the proposed design and operation best practices, they are encouraged to seek alternative means to achieve the same intent.



¹ Examples of commercial buildings include offices, shopping malls and buildings with retail components

02 Efficient Loading Bay

Efficient loading bay allow delivery operators to complete their deliveries within the shortest possible time. Commercial building owners and professionals can introduce a combination of strategies that minimise the volume of traffic queueing outside the buildings. These include reducing the turnaround time of vehicles at the loading bay and staggering the demand for the limited loading bay space throughout the day.

2.1 Weather Protection

A weather-protected loading bay that facilitates the delivery and receipt of goods at all times will prevent unnecessary monetary losses due to damage caused by inclement weather. This is especially important for loading bay that is located away from the main building.

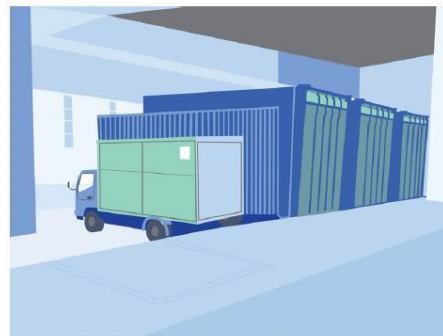

2.2 Ease of Access to Retail Outlets

Often, retail spaces are located across multiple building levels and this may result in delivery drivers having to traverse a few storeys to complete their deliveries. To facilitate a faster turnover of delivery vehicles, building professionals can consider the following questions in their designs:



Can the building afford to have the loading bay at the same level as the retail units with higher delivery volumes? (Note: Supermarkets and department stores would typically benefit from having their storage areas or receiving stations located next to the loading bay.)



Are the goods lifts located next to the loading bay?



Are the goods lifts designed to serve all retail shops?



Is there universal signage set up to direct delivery personnel to the designated goods lifts?



Are there any dedicated delivery corridors to guide the movement of goods from the loading bay to the delivery lifts?



Are the goods delivery corridors obstructed by any physical obstacles (e.g. building columns)?

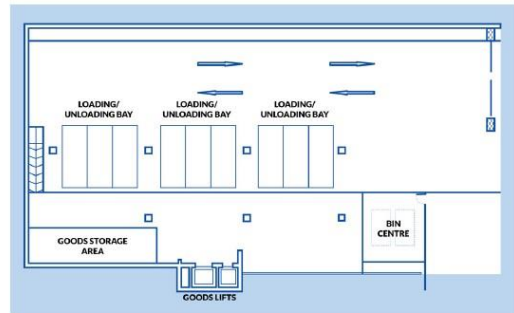

Floor Plan (For illustrative purposes)

2.3 Use of Goods Lifts



Commercial building owners are to ensure that goods lifts are reserved for cargo and delivery workers to load and unload goods. The prominent display of universal signage or the phrase, "For Goods Only", next to the goods lift in commonly-used languages can be considered.²

2.4 Storage Areas

Commercial building owners and professionals can consider setting aside storage areas next to the loading bay as an alternative to providing an individual storage area within the retail shop. Retailers can use these common storage areas to temporarily store their goods during their respective peak periods. In addition, commercial building owners can consider offering a "concierge service" to receive and deliver goods on behalf of their tenants as an additional benefit.

Commercial building owners and professionals can check with their potential tenants if the storage areas need to be customised for their use. Tenants such as supermarkets and department stores generally require the storage areas to be placed next to the loading bay platform to store goods and equipment such as hand pallet trucks and/or to double-up as a goods reception area.



2.5 Use of the Loading Bay

Loading bay is designed and reserved for vehicles performing deliveries or rendering services to the buildings. When designing the loading bay, commercial building owners and professionals can consider the following options:



Setting aside a fixed number of heavy vehicle and light goods vehicles parking lots based on the building's tenant mix to maximise the use of space. As a rule of thumb, food and beverage stores and supermarkets are likely to receive 6 times the delivery volume of other retail outlets.

Designating car parking lots for light goods vehicles (e.g. vans) during the buildings' off-peak hours can help to ease potential queues at the loading bay.



Peak Parking Demand



Off-Peak Parking Demand

² Commercial building owners and professionals may refer to the "SS 550 - Code of Practice for Installation, Operation and Maintenance of Electric Passenger and Goods Lifts" for more details on the standards for operating a goods lift.

2.6 Providing Clear Information

Making a clear set of information available to the driver will be useful for site orientation and help to improve the delivery turnaround time of the vehicles. Commercial building owners can consider sharing the following information:



Building Layout Plan
This is advisable for larger buildings that are potentially more challenging for drivers to navigate and identify the stores.



Parking Charges and Grace Period
It is advisable to provide a grace period of 30 minutes for delivery vehicles, after which a higher step-up charge will be imposed. This will deter delivery drivers from overstaying at the loading bay. For delivery operations that require more than 30 minutes, commercial building owners can recommend for such deliveries to take place during off-peak periods (e.g. night deliveries).



Estimated Number of Available Lots or Waiting Time
Clear signage that indicates parking availability can help delivery drivers better estimate the time required to wait outside the loading bay. In the long run, this information can be shared "live" with delivery companies to help them optimise their delivery scheduling activities.



Restricted Delivery Days/ Timing
As a rule of thumb, the narrower the delivery restriction window, the higher the likelihood of delivery vehicles bunching outside the loading bay. Instead of having restricted delivery hours/ days, commercial building owners should aim to stagger delivery volume across different time frames by using a dock scheduling system (see point 2.7).

03 Improving Traffic Safety And Goods Flow

3.1 Delivery Ingress and Egress

It is good practice for commercial building owners and professionals to keep:



a) The ingress and egress lanes of passenger vehicles from the goods vehicles as far apart as possible.



b) The driveways of both in-coming vehicles and out-going vehicles separate.

Commercial building owners and professionals can choose to provide separate ramps or provide a 2-way driveway to prevent gridlock between different traffic user groups. In addition, signage leading into the loading bay must be displayed prominently and be visible at all times.



2.7 Leveraging on IT systems

The use of software tools like dock scheduling/ booking and queue management systems can help commercial building owners obtain better control and management over the building's delivery schedule. With greater certainty over their loading bay lots availability, this can reduce queueing and minimise conflicts between delivery vehicles and other traffic.

In addition, commercial building owners can allow for pre-security clearance through the booking system, thus removing the laborious procedure on-site. Through the system, commercial building owners are encouraged to practice differential pricing when managing loading bay usage.



3.2 Designing the Loading Bay Access Point

Sometimes, the ingress and egress of a loading bay may intersect with pedestrian movement and lead to undesirable conflicts between vehicles and pedestrians. Commercial building owners and professionals are therefore advised to use traffic calming devices and design strategies to alert motorists of potential pedestrian activity. Some examples include speed humps, visual changes to reduce speed and curb extensions (bulb-outs) to narrow the width of roadways at crossings. Motorists are also required to have a clear line of sight when exiting loading bay ramps.

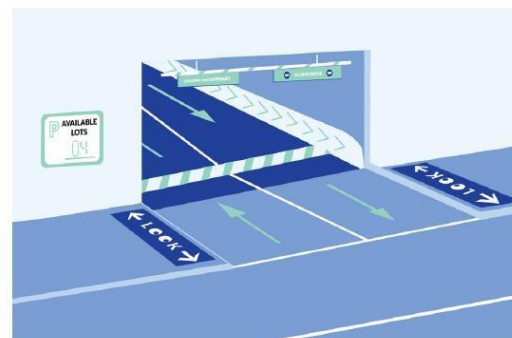

3.3 Designing the Loading Bay Platform

Loading bay platforms allow delivery personnel to unload their goods from the vehicles in a fast and efficient manner. Commercial building owners and professionals can consider installing dock levellers or varying the height of the loading bay platform to cater to different delivery vehicles sizes. When deciding the types of loading bay platform to be provided, the following questions can be considered:



What is the proposed building's tenant mix and expected delivery volume? Vehicles with higher delivery volume are likely to require a loading bay platform.



The estimated proportion of 'business to business deliveries' and 'business to consumer deliveries' will result in different mix of heavy and light goods vehicles entering the building. This will affect the height of the loading bay platform to be provided.

Besides the loading bay platform, access ramps with safety barriers are required for vertical transportation of goods up and down the loading bay platform. The loading bay platform is to be kept clear at all times to ensure the smooth delivery of goods and prevent hazards (e.g. fire) from taking place.

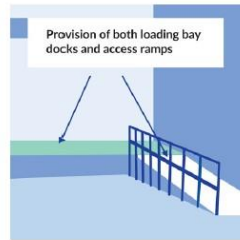

Such practices will help to maintain the hygiene level of the loading bay and prevent unnecessary contamination of food products.



Commercial building owners and professionals should also set aside enough space within the building for these needs:



Skip bins



Recyclables⁴



Storage areas for roll cages or other retail goods

⁴ For guidelines in the design for collection of recyclables for malls, mall owners and professionals can take reference from the requirements for residential units found within the Code of Practice on Environmental Health.

3.4 Managing the Refuse Storage and Collection System

In most cases, the loading bay is located near the refuse storage and collection system,³ such as the refuse bin centre. Commercial building owners and professionals are advised to:



Keep the loading bay and waste collection points as far apart as possible.



Ensure the bin centre's shutter doors are closed at all times except during refuse truck collection or waste disposal.



Maintain the regular upkeep of waste collection points and the loading bay.



Ensure that any inspection chambers or grease traps are not located within the loading bay.

³ Commercial building owners and professionals are to refer to the National Environment Agency's latest Code of Practice on Environmental Health (COPEH) on the requirements and design of these refuse storage, collection systems and location of grease traps.

3.5 Positioning of Loading Bay Barriers

Loading bay barriers are useful for preventing congestion within the loading bay by limiting the number of delivery trucks entering the building. However, the barriers need to be located within the building to prevent queueing traffic from spilling onto the main road and causing inconvenience to other road users. Commercial building owners and professionals are advised to place their loading bay barriers as far inside a building as possible to achieve the longest queue. In addition, the drop-barrier should not be positioned along an upward ramp, within a circular ramp or immediately after a bend.

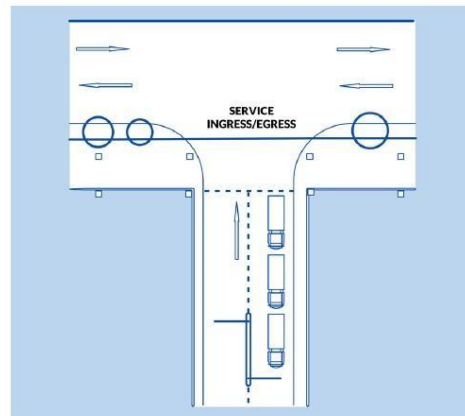

3.6 Protection of Building Interior Along Delivery Corridors

Commercial building owners and professionals can consider installing protection for lifts, door frames and walls that are easily damaged. This can help minimise unintended damage to the building interior caused by the high traffic of goods delivery and services. Some of these options include bumper rails, wall protection rails, skirting boards and/or diamond plate.

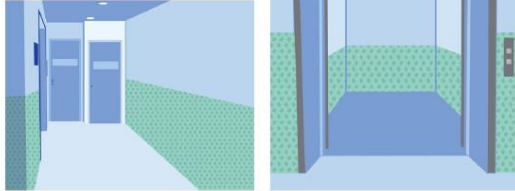

3.8 Lighting

Good lighting enables people to see and perform their tasks safely and efficiently. Good lighting is dependent on how the light is delivered, the colour of the light source and the level of glare from the system. Commercial building owners and professionals are to ensure sufficient illumination at the loading bay.⁵

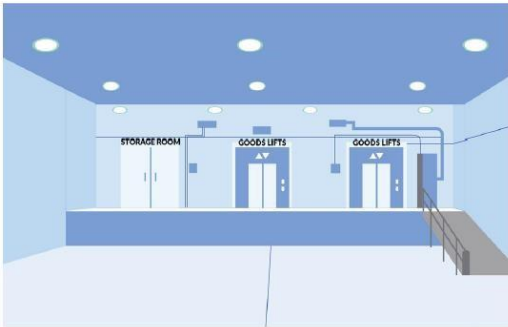

⁵ Commercial building owners and professionals can refer to the "SS531: Part 1: 2006 - Code of Practice for Lighting of Workplaces" for the recommended illumination under different conditions.

3.7 Protection of Structural Building Columns at the Loading Bay

Structural building columns located within the loading bay are subject to risk of vehicular impact that may be incurred from the reversing of vehicles. Commercial building owners and professionals may either design the column to withstand the vehicle impact load or provide an additional layer of physical protection to absorb the force from vehicular impact.⁵ These physical protections shall be design in a way that do not reduce the driveway widths or parking aisles.

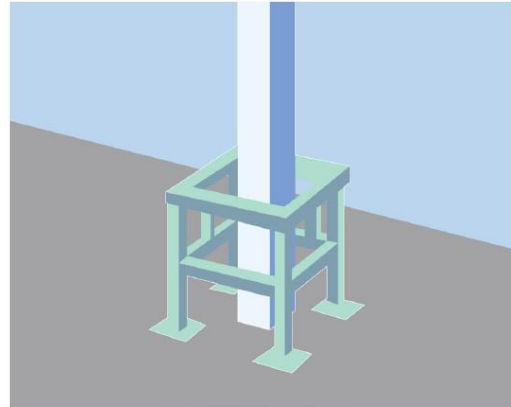

⁵ Commercial building owners and professionals can refer to the "SSEN1991-1-7: 2009 on General Actions - Accidental Actions" for recommended approaches to protect the structural building columns.

04 Adapting To Changing Delivery Trends

4.1 Vehicular Goods Lifts



Commercial building owners and professionals might have opted for vehicular goods lifts instead of a ramp to provide loading bay access on floors other than the ground level. In such cases, commercial building owners are advised to develop a contingency plan for alternative delivery arrangement when the lifts are not available (e.g. routine servicing of lift, lift breakdowns, etc). Some of these temporary arrangements can include sharing loading bay lots with neighbouring buildings and the temporary conversion of parking lots for light goods vehicles to load and unload.

4.2 Noise and Fumes Mitigation



Goods deliveries can cause noise and fumes nuisance to the public, including nearby residences. Potential noise nuisances include engine noise from vehicles travelling up steep ramps, reversing alarms, idling engines, use of equipment for loading/unloading (e.g. hand pallet trucks), delivery of roller cages over durbar plates and community noise due to the congregation of delivery personnel.

The design of loading bays should incorporate mitigation measures to abate such noise nuisances. This can include:



Ensure that the loading bay faces away or is shielded from any nearby residential buildings, or situated within the building (e.g. in the basement)



Install the use of sound-absorbing sheets or sound-dampening materials to minimise the noise generated for deliveries occurring at late night or early morning deliveries



Install signage at loading/unloading bays to remind the delivery drivers to switch off the engine when the vehicle is stationary, with the exception of chiller/refrigerated trucks



Parking Location for Active Mobility Devices (e.g. bicycles, power-assisted bicycles, personal mobility devices) ⁷

Commercial building owners and professionals are to identify suitable parking locations within their buildings and explore the following practices:

- Locate parking lots close to food and beverage shops to facilitate faster delivery turnaround time. For existing buildings, commercial building owners can convert these lots from excess parking lots, dead spaces or communal spaces.
- Provide security measures such as the installation of CCTVs or steel racks for bicycle/ Personal Mobility Device parking to deter crime within the building premises.



4.3 Managing Short-Term Food Deliveries

The food delivery sector has grown rapidly in recent years and will continue to expand. Commercial building owners who have high residential or commercial mix can consider designating a collection point near the delivery parking areas for their tenants to collect these deliveries.

In addition, the design of the food and beverage outlets or building layouts can be optimised for the receipt of food delivery orders. This could include a dedicated queuing/ waiting area for the delivery riders or creating a separate food collection point.



Parking Location for Motorcycles ⁷

Commercial building owners and professionals can consider either setting aside motorcycle parking lots for food delivery riders or allowing them to park temporarily at the building's loading bay. This is to prevent the indiscriminate parking of motorcycles. Commercial building owners can also consider providing a reasonable grace period (e.g. 15 minutes) ⁸ or parking waivers for food delivery riders to collect food deliveries.

⁷Commercial building owners and professionals are to refer to the Land Transport Authority's Code of Practice on Vehicle Parking Provision in Development Proposals, for the provision and design guidelines for motorcycle and bicycle parking facilities.

⁸Time taken for most delivery riders to collect their deliveries. Data collected across 3 major food delivery operators in May 2019.

05 House Rules

Commercial building owners are advised to develop their own house rules and display them clearly for the delivery drivers and food delivery riders. These house rules can be displayed at the respective parking locations or at the goods lift. The house rules should articulate what is permissible within the buildings and include the following:





- Designate parking locations
- Process for pre-security clearance or security clearance (if any)
- Designate smoking corners and resting areas
- Building operator hotline for feedback
- Risks and liabilities for theft, loss or damage of vehicles or mobility devices
- Penalties for non-compliance

For food delivery riders, additional house rules could be applied:

- **MAX CAPACITY 15** Max number of food delivery riders allowed to gather while waiting for orders
- **NO ALCOHOL** Use of active mobility devices (e.g. bicycles) within the buildings

06 Checklist

| LOADING BAY BEST PRACTICE | DESIGN | OPERATION |
|--|-----------------------|-----------------------|
|  Ensure loading bay is weather-protected | <input type="radio"/> | |
|  Ensure ease of access from loading bay to retail outlets, especially for supermarkets and department stores | <input type="radio"/> | |
|  Use of goods lifts | | <input type="radio"/> |
|  Provide goods storage areas | <input type="radio"/> | |
|  Set aside loading bay lots for use by both heavy and light goods vehicles | <input type="radio"/> | |
|  Designate car parking lots for light goods vehicles during non-peak hours | | <input type="radio"/> |
|  Display Signages: Building layout Plan, parking charges and grace period, estimated queue time or number of available lots | <input type="radio"/> | <input type="radio"/> |
|  Use IT systems to manage loading bay | | <input type="radio"/> |
|  Ensure no potential gridlock between passenger and goods vehicles circulating within and outside of the buildings | <input type="radio"/> | |
|  Install traffic calming devices or design signals to alert motorists of potential pedestrian crossing at the entrance/ exit of loading bay | <input type="radio"/> | |
|  Determine the need for a loading bay platform based on tenant mix | <input type="radio"/> | |

| LOADING BAY BEST PRACTICE | DESIGN | OPERATION |
|---|-----------------------|-----------------------|
|  Ensure proper design and management of refuse storage and collection system by setting aside space for skip bins and recycling points | <input type="radio"/> | <input type="radio"/> |
|  Position loading bay barriers to allow for traffic queuing on vehicular ramps | <input type="radio"/> | |
|  Protect the building interior from delivery accidents | <input type="radio"/> | |
|  Protect the structural building columns from vehicular impact | <input type="radio"/> | |
|  Ensure sufficient illumination at the loading bay | <input type="radio"/> | <input type="radio"/> |
|  Develop a contingency plan for alternative delivery arrangement (for buildings with goods lift) | | <input type="radio"/> |
|  Design loading bay to mitigate noise and fumes: - Rubberised/ dampened flooring throughout the loading/ unloading area and the delivery route - Install signage/ posters to remind operators to keep noise to a minimum after operating hours - Signage installed at loading/ unloading bays to remind delivery lorry drivers to switch off their engines, when stationary | <input type="radio"/> | <input type="radio"/> |
|  Design food and beverage outlets or building layouts to optimise the receipt of food delivery orders | <input type="radio"/> | |
|  Designate parking locations for food delivery riders | | <input type="radio"/> |
|  Develop house rules and display them clearly at the parking locations or at the goods lift | | <input type="radio"/> |



45 Maxwell Road
The URA Building
Singapore 069118

www.ura.gov.sg | [Facebook](#) / [Twitter](#) / [Instagram](#) / [LinkedIn](#) / [Telegram](#)

Receive our monthly updates: ura.gov.sg/subscribe

1. What type of buildings would the guide be applicable to?

The guide has been designed together with industry experts, for commercial buildings such as offices, shopping malls and buildings with retail components. Nonetheless, other types of buildings, such as residential, are also highly encouraged to apply the suitable best practices where applicable.

2. Will it be compulsory for buildings such as shopping malls to adopt the measures mentioned in the guide?

While it is not mandatory, existing commercial buildings are highly encouraged to refer to the guide for operational best practices and adopt the design best practices when there are major refurbishments. Building owners, developers and QPs can adapt the best practices to suit the site constraints and development's needs.

3. Is there a deadline for the commercial buildings to adopt any of the best practices?

There is currently no fixed date to adopt any of the practices. However, building owners who face difficulties in managing the loading bays (which may have led to enforcement actions or complaints from the public), are highly encouraged to adopt the best practices mentioned in the guide.

4. Will there be any financial subsidies to help existing buildings adapt their current loading bay facilities to be in line with the guide?

As part of ESG's mandate to help retail buildings grow through capability upgrading and business transformation, grant support scheme is in place for building owners to adopt the use of dock scheduling/ booking and queue management system to manage the loading bays, subject to its approval. These grants are subject to reviews by the overseeing agencies and may undergo changes without prior notice. Applicants can write in to [ESG](#) to enquire.