

DIGITALIZED HIV SCREENING

MEMBERS: SSN MELVIN KHOR, SSN CELESTE CHNG, MS BHARATHI BALAKRISHNAN & MS MARGIE LIAN
ADVISORS: ADON NANCY YEO, ADON NG WEI WEI

- SAFETY
- QUALITY
- PATIENT EXPERIENCE

- PRODUCTIVITY
- COST

Define Problem, Set Aim

Problem/Opportunity for Improvement

The paper HIV data collection was extremely manual and time consuming for both inpatient nurses and nursing admin staff. It accounts an average of 20% compliance rate in HIV screening submission. It also compromises data entry due to compliance rate and prone to human errors during data extraction.

Aim

- To improve 100% of efficiency and effectiveness of HIV data collation and extraction through digitalization.
- To provide accurate and timely HIV data to MOH.
- To support the eco-environment through saving paper and saving tree.
- To improve staff satisfaction.

Establish Measures

Outcome measure

In year 2022, out of 30, 235 patient admission, only 12% (3,909) of the paper HIV screening forms received from NTFGH wards. In the 2nd quarter of 2023, out of 8,080 patient admission, 34% (2,751) forms were submitted digitally.

Process measure

Digital submission via HIV FormSG.

Balancing measure

100% submission of digital HIV screening forms from all NTFGH wards.

Analyse Problem

CURRENT PROCESS FOR PAPER HIV SCREENING

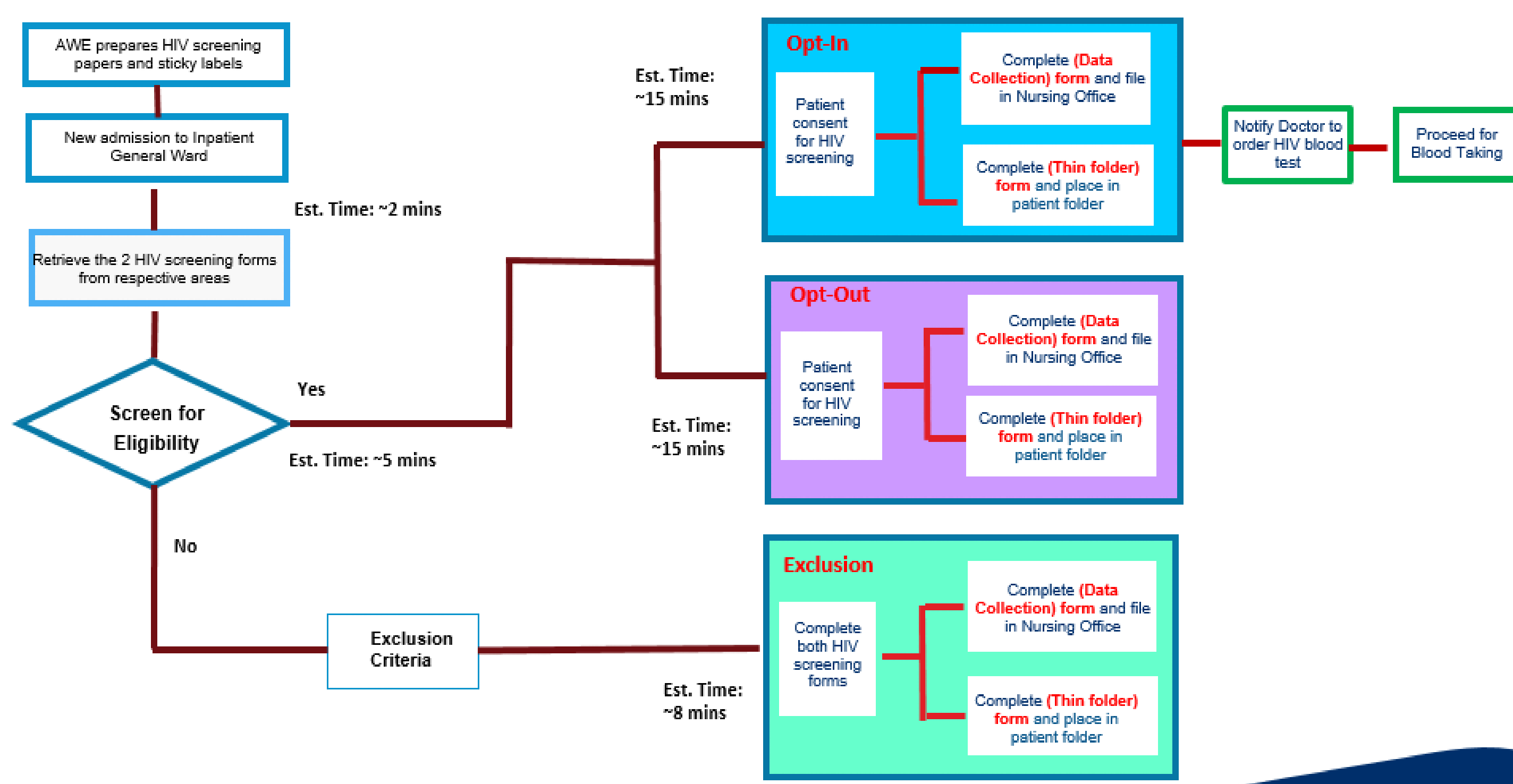

Implement Changes

PROPOSED PROCESS FOR DIGITAL HIV SCREENING

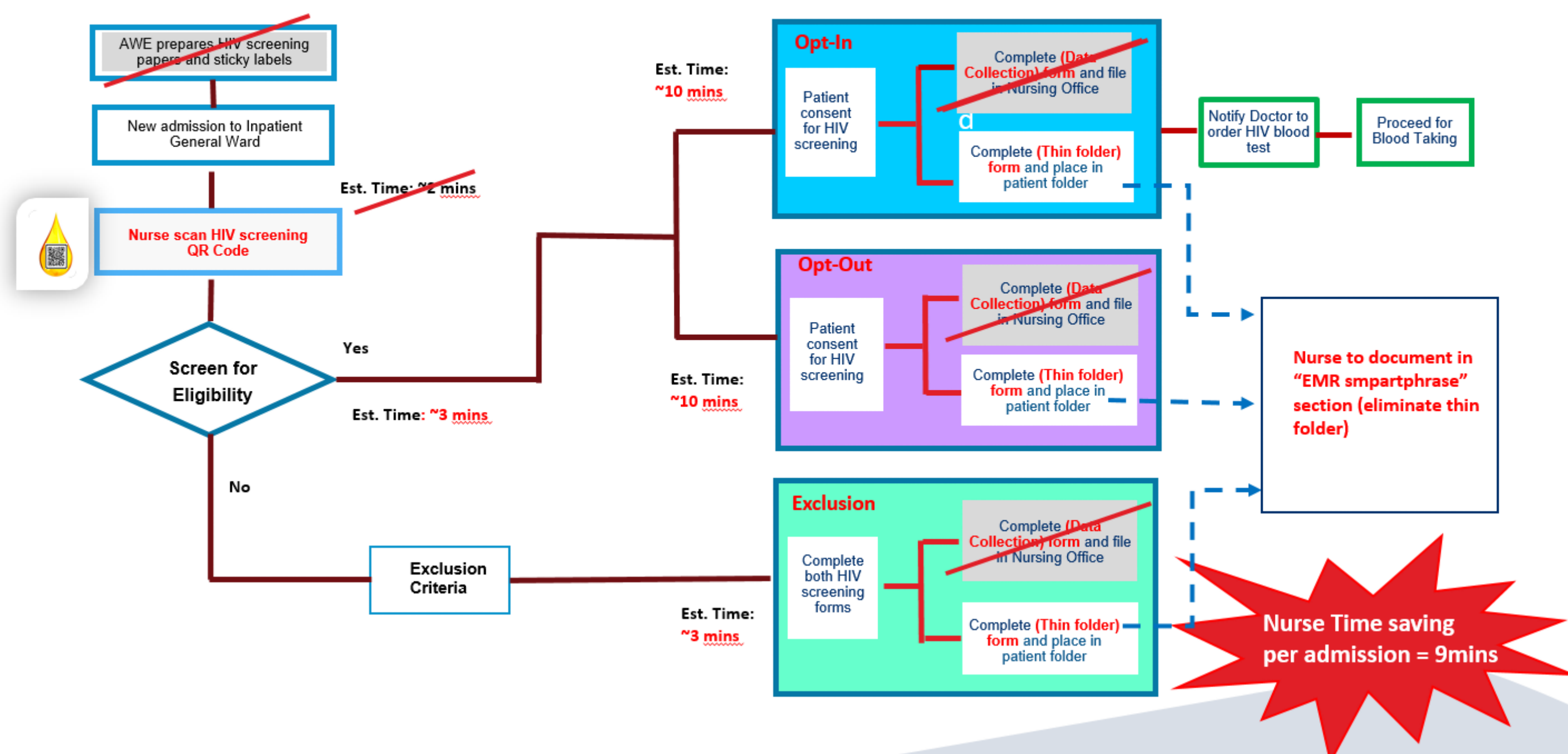

Implement Changes

Scope	Timeline	Status
1 Pilot in B9S & B10S	Mar- Apr 2023	<ul style="list-style-type: none"> • Pre-Survey: 27 Feb-5 Mar 2023 • Post- Survey: 3-9 Apr 2023 • Discussed to streamline process • Design QR code and FormSG
2 Showcase Pilot & Communication	April – May	<ul style="list-style-type: none"> • Design recipe card • Launched QR code in Intranet • Revised FormSG • Presented to COO and NLM
3 Spread	May to present	100 % roll out to NTFGH wards

Recipe Card: Digitalized HIV Screening for Inpatient Ward

Objectives:

- To improve the efficiency and effectiveness of HIV data collation and extraction through digitalization.
- To support the eco-environment through saving paper and saving tree.

Process:

To adopt the HIV screening questionnaire QR code and document in EMR by using 'SMARTPHRASE': .HIV

Exclusion Criteria:

- Unconscious/Unfit
- Admit to ICU/Isolation Ward
- Renal Dialysis
- Police case: Cat A / B
- HIV test done < 5 a year
- Work Permit holder

Opt In / Out:

- Patient age ≥ 21 above
- Singaporean or SPR

Document in EMR by using 'SMARTPHRASE': .HIV

Process Owner: ADON Nancy Yeo & Ag ADON Ng Wei Wei
Last Updated on 28 April 2023

Results

Year 2022					
	Q1	Q2	Q3	Q4	Total
No. of patient admission	6238	7445	8576	7976	30,235
Opt Out + Exclusion	654	1060	524	342	2580
Opt In	419	317	350	243	1329
	1,073	1,377	874	585	3,909

Year 2023					
	Q1	Q2 *	Q3	Q4	Total
No. of patient admission	8244				
Opt Out + Exclusion	551				
Opt In	29				
	580				

Count of Ward	Column		Grand Total
	May	Jun	
WB3S	64	109	173
WB5P	26	55	81
WB5S	94	160	254
WB6P	21	52	73
WB6S	74	99	173
WB7P	7	28	35
WB7S	78	107	185
WB8P	33	33	66
WB8S	53	75	128
WB9P	31	44	75
WB9S	104	113	217
WB10P	34	82	116
WB10S	53	66	119
WB11S	36	51	87
WB12S	34	28	62
WB13S	41	45	86
WB14S	34	81	115
WB15S	4	97	101
WB16S	72	101	173
WC7S	63	86	149
WC8S	52	84	136
WC9S	54	72	126
Grand Total	1062	1668	2730

*Digitalization of HIV Screening commenced on 8 May 2023

Spread Changes, Learning Points

Spread Changes

'Show & Tell' to Nurse Leaders, on reason for change & result achieved at pilot wards
Spread to all Inpatient wards in NTFGH with NI Champions.

Key Learning

In future, this can be a sub-requisite embedded in EMR 'Navigator: Admission Tab'.