

UVC Germbuster

Author: Christopher Willis

Co-Author: Stewart Tai & Syafiq Yeoh & Keegan Lim & Edgina Winartio

Background & Aims

- Hospital bathrooms are known to contain a high number of microorganisms, including multi-drug resistant organisms (MDRO). This reservoir of pathogens can spread among patients and lead to serious infections.
- Blind spots which are left untouched by Environment Service Associates are optimal spots for bacteria to grow.
- Improvement of hospital hygiene is needed for patient safety.
- Aim – To find an effective way to reduce bacterial counts in the washrooms without the use of manpower.

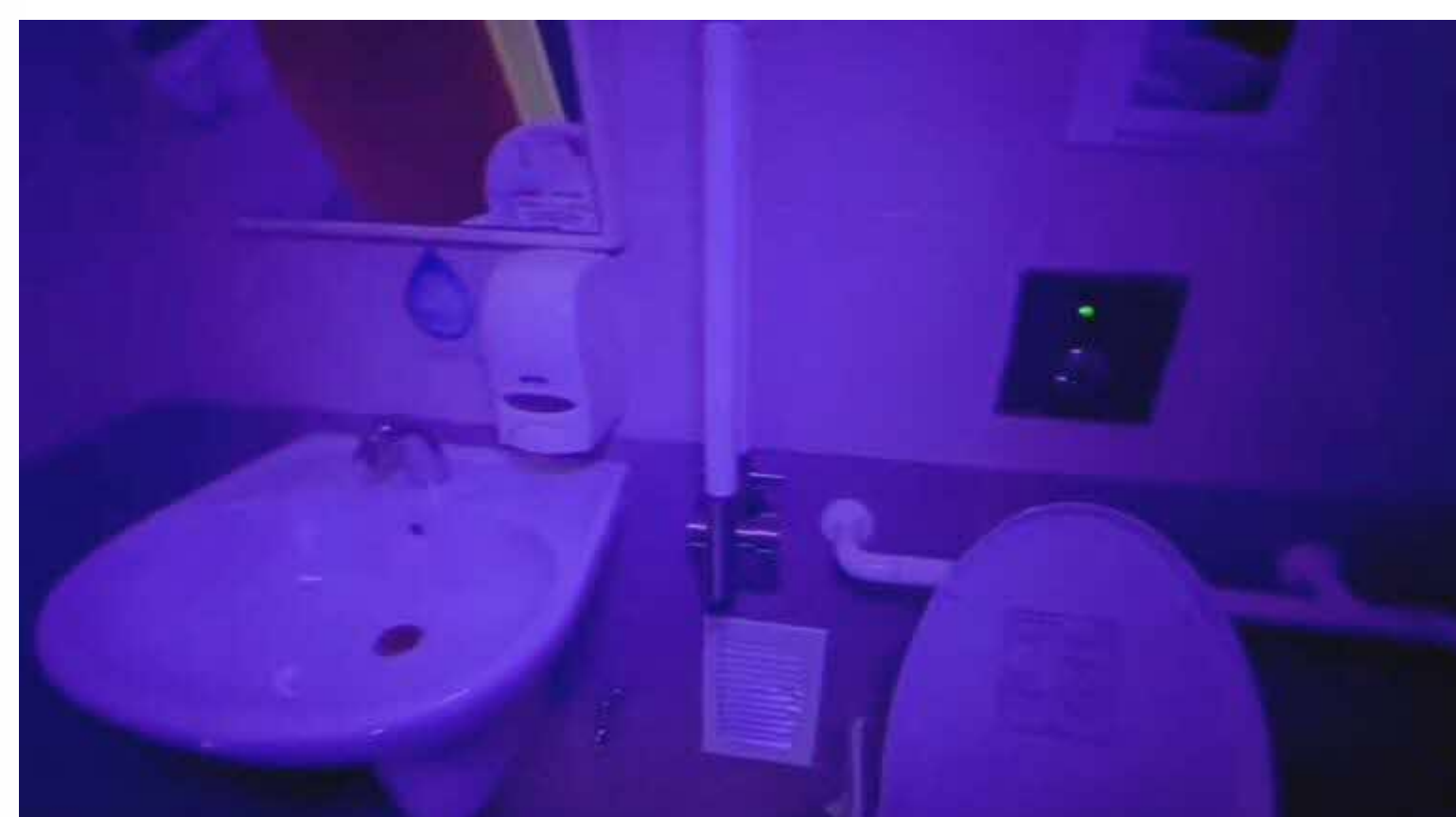
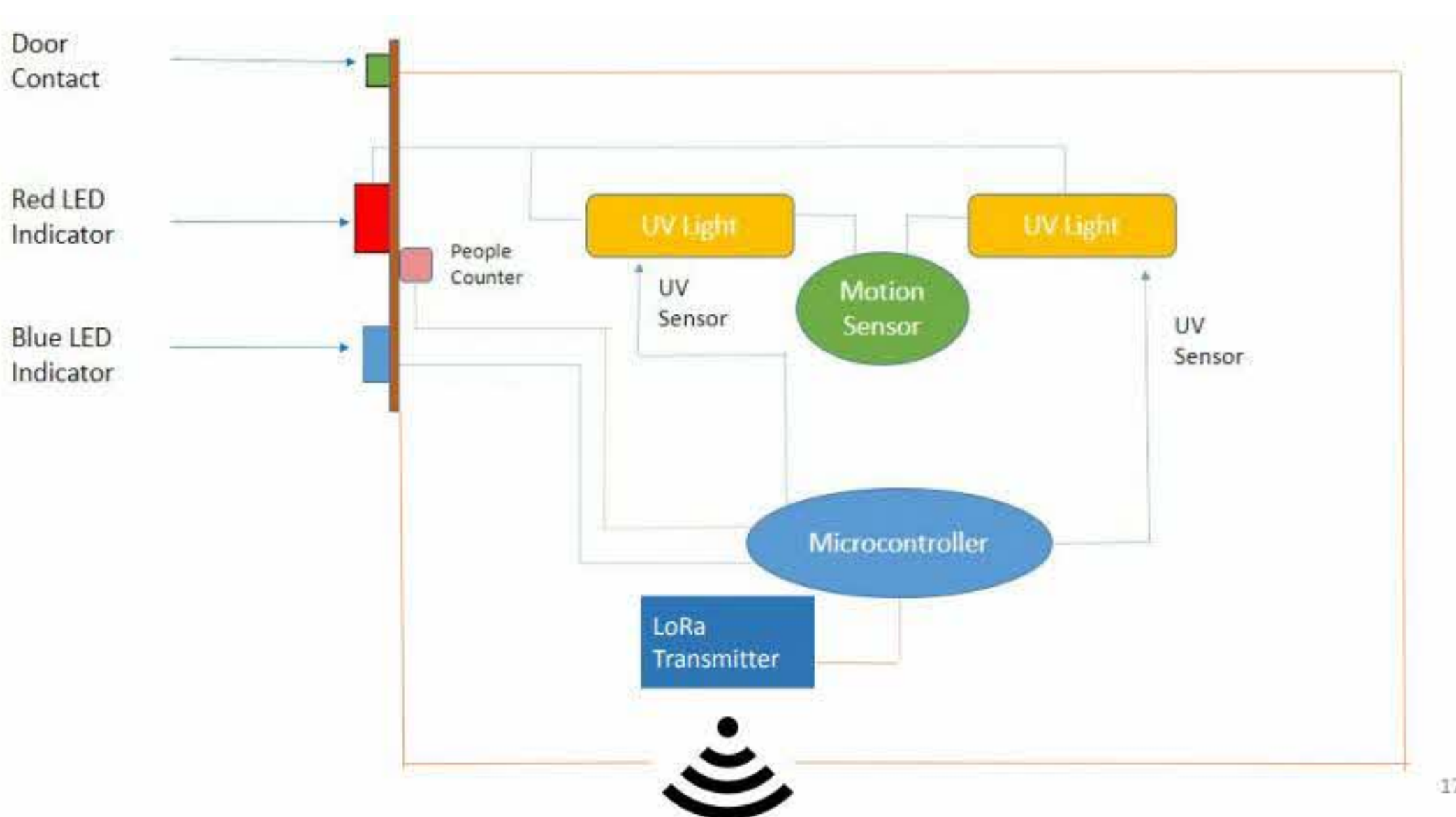

Results & Project Impact

- Since implementing the UVC light system, the number of harmful microorganisms have significantly decreased. This has been confirmed by an accredited laboratory which tested before-after swab tests from a ward toilet. This UVC system can reduce bacterial counts to extremely low levels..
- This project will enhance patient and nurses' safety and instill a better safety awareness culture.
- Staff ratio is maintained as this system does not require extra manpower to operate, nor would extra staff be necessary to clean the ward toilets.

	Grab Bar in Toilet	Inner Door Handle & Lock	Sink	Soap Dispenser	Shower Handle	Shower Chair	Grab Bar At Shower Area	Shower Control Water Knob	Cloth Hanger	Toilet Cover
0 Min	50	40	6,400	380	880	14,000	17,000	7,600	<10	12,000
5 Mins	<10	<10	190	<10	300	12,000	1,500	210	<10	30,000
10 Mins	60	<10	9,000	<10	<10	520	3,200	300	<10	6,200
15 Mins	<10	<10	140	<10	<10	1,200	800	200	<10	2,000
Effect by 15 Mins	↓ 5	↓ 4	↓ 46	↓ 38	↓ 88	↓ 12	↓ 21	↓ 38	-	↓ 6
Effect by 10 Mins	↓ 1	↓ 4	↑ 1	↓ 38	↓ 88	↓ 27	↓ 5	↓ 25	-	↓ 2

Methodology

- In response to an increase in antibiotic-resistant hospital-acquired infections, the Infection Control Committee and Team explored methods to break the chain of microorganism transmission among patients. Shared toilets/showers are reservoirs of bacteria in view of high humidity
- UVC light is a potent germicidal for bacteria, viruses, fungi, and parasites. We designed a simple and low-cost system to be installed in shared patient toilets. After Senior Management approval, and after obtaining grant funding for our prototype, we installed the system in two toilets/shower areas on ward B65 at KTPH. It employs two ceiling-mounted UVC light tubes which turn on when the toilet door is closed and nobody is inside. The toilet door is spring-loaded so that it always closes fully after entry or exit.
- Three safety features ensure patients and staff will not be inadvertently exposed to UVC light. 1. Spring-loaded door closure with automatic turnoff of UVC whenever the door is opened. 2. A motion detector prevents the UVC from turning on whenever someone is inside. There must be no motion detected for 15 minutes before the UVC turns on. 3. An entry/exit person counter ensures the UVC will not turn on in the unusual situation where a patient was to lose consciousness in the toilet.
- An LED light on the outside of the toilet shows the UVC light is on.
- Swabs of high-touch points were taken before UVC activation and repeatedly for three times after every 5 minutes of activation (ie. 5,10,15 minutes UVC exposure). These were sent to an accredited lab to determine colony counts. Results are shown. Colony counts can be expected to be even lower when the system is operating 24/7 because bacteria and other germs have no time to multiply.

Sustainability & Follow-Up

- New nurses will be briefed on the UVC system by the nurse in-charge.
- Pictorial guides are pasted on the door for staff and patients to understand the system.
- The UVC Germbuster system is entirely automated. It will include a fault-detection system which allows central monitoring and prompt rectification of any problem by Facilities Management.



Conclusion

- This automated, low-cost, effective and reliable system will greatly enhance patient and staff safety. Environment Service Associates will be able to focus on other things than cleaning the toilet. It will limit the need for more manpower.