

# National University Health System (Singapore)

## Automated Diagnosis of Appendicitis Based on Clinical Notes

Category: Automation, IT, Robotics Innovation

Authors: A/Prof Kee Yuen Ngiam, et. al

Department: NUHS AIO-Innovation Office, Group Chief Technology Office

**Aim:** The main objective of this project is to develop a deep learning AI system to aid in the diagnosis of appendicitis during A&E admissions by giving appendicitis diagnosis recommendations to doctors.

### How it works:

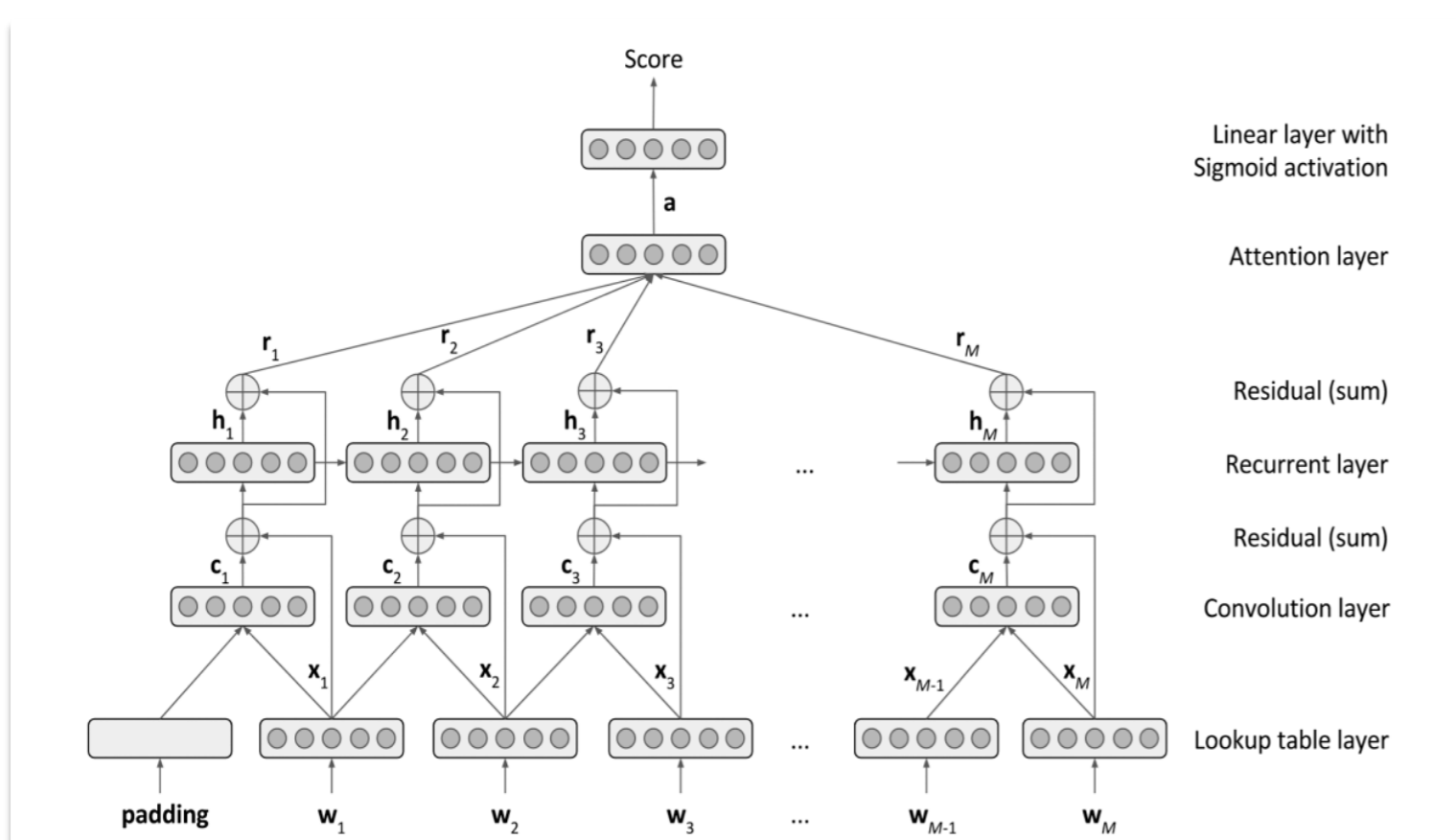

Fig 1: Overall architecture of the model

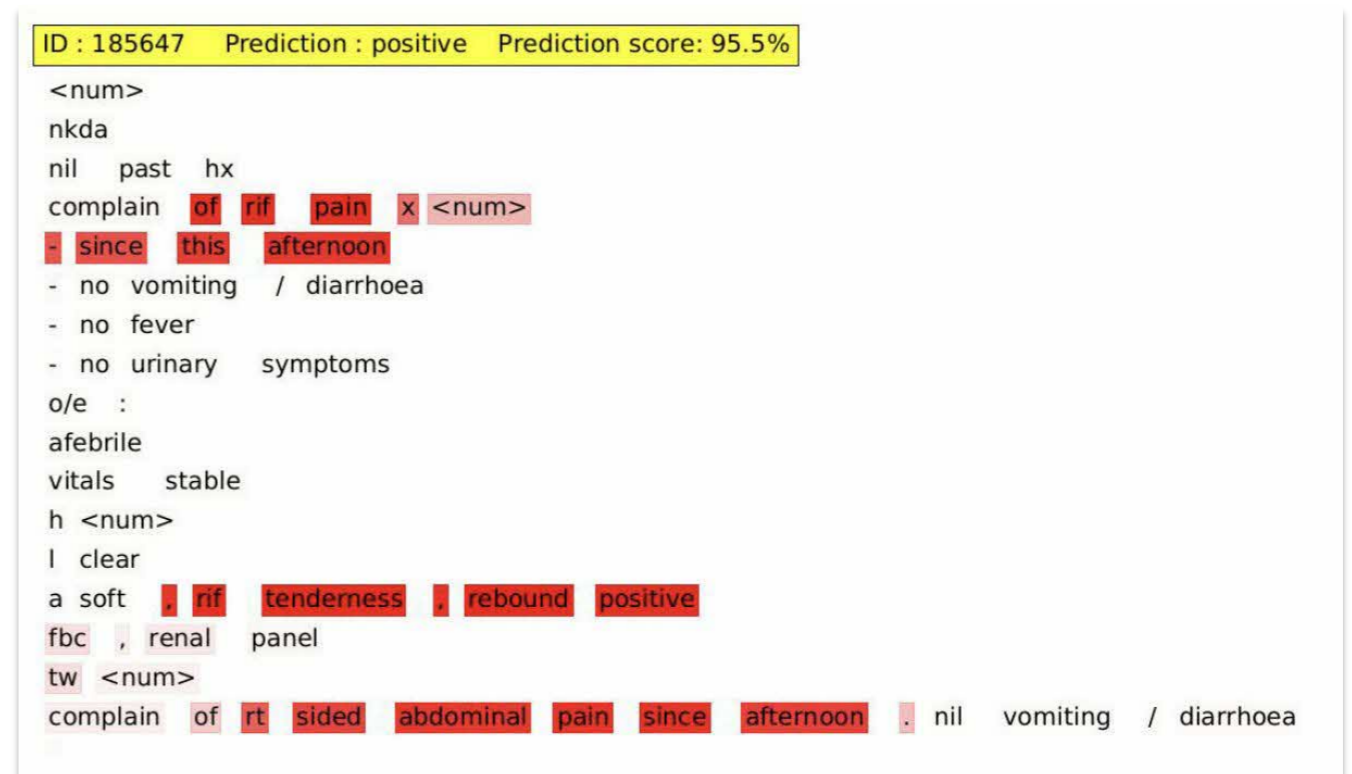

Fig 2: Highlights on important keywords

We utilized a combination of convolutional neural network (CNN), recurrent neural network (RNN), and residual network inspired by their successes in multiple tasks. RNN has proven to be successful in sequence prediction tasks such as speech recognition, image caption generation, machine translation, automated essay scoring, and human dynamics. CNN has also been very successful in image classification, and natural language processing. In our work, we used the CNN layer to extract local features and the attention layer to visualize high importance words (refer to Fig 2). The darker the shade of red, the important the model deems the word to be for the prediction.

### Outcome and Sustainability:

A randomized clinical trial was conducted to evaluate the model in clinical setting. The F1 score for clinicians' prediction for appendicitis was 0.58 whereas the machine performed at 0.51. Although the machine did not perform as well, the F1 score was 0.61 (intervention group) when the clinicians made use of the machine to make their prediction. The tool had a larger impact on junior doctors who saw a positive improvement of their prediction score when they used the tool. Senior doctors saw little to no change while making use of the tool to make their decisions. In conclusion, the tool enhanced the overall performance of the clinical decision-making.